



Bringing Scientific & Technical
Resources to the Africa Continent

FILTRATION & MICROFILTRATION

NEW POSSIBILITIES IN FILTRATION



CHMLAB Group is a specialized company in separation, filtration and purification products with the aim to fulfil the customer requirements in the scientific community.

Our innovative and high-quality products help customers in laboratories and processes in a time- and cost-efficient way. Our vision is to provide the best quality and high-end performance products.

Our key customers are from industries of bioscience, pharmaceutical, medical and food, as well as universities, public research institutes and laboratories.

Chrom Africa Instrumentation Services Limited

Buruburu Business Complex Suite No.26, Mumias South Road, Nairobi.

P.O Box 4963-00100, Nairobi, Kenya.

Phone number: (20) 2594918



CHMLAB was founded in 2005 , has its head office in Barcelona, and operates worldwide through local partners in more than 65 countries.

The specialized reliable distributors around the world provide efficient support to the customers and have a deep understanding of the customer needs.

Due to our overseas policy we are always expanding to new markets and looking for new distributors to promote our products and cover bigger regions.

Email info@chromafrica.co.ke | info@chromafrica.com
Website: www.tchromafrica.co.ke | www.chromafrica.com





INDEX

01	FILTRATION	6
02	MICROFILTRATION	44
03	SPECIALITIES	108
04	CROMATOGRAPHY	134
05	INDUSTRIAL FILTRATION	162
06	CAPSULE FILTERS	170
A	APPENDIX	180

01

FILTRATION

1.1	Quantitative filter paper	9
1.1.1	Ashless filter paper for quantitative analysis	9
1.1.2	Ashless hardened filter paper for quantitative analysis	12
1.1.3	Hardened low ash filter paper for quantitative analysis	14
1.2	Qualitative filter paper	16
1.2.1	Ashless hardened filter paper for qualitative analysis	16
1.2.2	General-purpose qualitative filter paper	19
1.3	Special filter papers	22
1.3.1	Activated carbon paper	22
1.3.2	Paper with diatomaceous	23
1.3.3	Filter paper free of K and P, low of N	24
1.3.4	Black filter paper	25
1.3.5	Paper for fat analysis	26
1.4	Glass microfiber filters	27
1.4.1	Glass microfiber filters without binders	27
1.4.2	Glass microfiber filters with binders	30

1.5	Quartz microfiber filters	32
1.6	Extraction thimbles	34
1.6.1	Cellulose extraction thimbles	34
1.6.2	Glass microfiber thimbles	36
1.6.3	Quartz microfiber thimbles	37
1.7	Filter paper for surface protection	38
1.7.1	Filter paper in reams	38
1.7.2	Absorbent paper with Polyethylene	39
1.8	Phase separation paper	40
1.9	Technical filter papers for special analysis	41
1.10	Ph indicator and test papers	43

01

FILTRATION

Filtration is the mechanical-physical operation which is used for the separation of solids from fluids (liquids or gases) by interposing a porous media through which only the fluid can pass. Oversized solids in the fluid are retained on the surface as well as within the matrix of the filter media.

Filtration has a wide range of applications: from laboratory analytical procedures to techniques in big production lines.

Type of Filters

Filter Paper

- Quantitative and qualitative analysis
- General laboratory procedures (clarifying filtration)
- Technical applications
- Special applications

Glass and Quartz Microfiber

- Very small particles
- Aggressive substances
- Temperatures up to 500 and 900 °C
- Water analysis
- Biochemical determinations
- Air monitoring
- Used as a membrane pre-filter

Extraction Thimbles (Cellulose, Glass & Quartz Microfiber)

- Extraction solid/liquid with Soxhlet
- Powder and aerosol particles collection in gases

Filter papers retain the impurities or particles of the liquid fluids on the surface as well as within the matrix of the filters.

The particles or impurities are settled into the filter modifying its filtration properties. Within the filter fibers arranged in an anarchic way into the filter paper, it creates a secondary filtration layer.

This is the reason why it is not possible to determinate a nominal porosity for the filter papers.

As guidance, it is possible to find the retention ranges into our technical specifications tables.

Often the filter papers are named as depth filters; they have a high capacity to retain particles and allow to process big quantities of sample.

1.1 Quantitative filter paper



1.1.1 Ashless filter paper for quantitative analysis

These CHM® filter papers are used for quantitative analysis and designed for preparation of samples and gravimetric analysis. They are made of refined pulp and linters with virtually 100% of alpha-cellulose content. These filter papers are guaranteed free of possible residual acids used in some production methods.

Extremely low percentage of ash content (maximum ash content of <0.007%).

Ashless filter papers for quantitative analyses are suitable for Büchner funnels and for filtration under vacuum.

F2045 GRADE – Very fast filtration

Filter paper of very high rate of filtration, wide-pored, soft, spongy structure, extremely low-ash content.

Food industry applications: determination of ash contents and PCB determination in foodstuffs.

Beverage industry applications: processing (ashing) fruit juice samples for photometric determinations (e.g. phosphate).

Environmental analysis: Determination of filterable substances and the residue on ignition (dry weight) for the examination of water, wastewater and sludge (DIN 38 409 part 2).

F2041 GRADE – Fast filtration

Fast ashless filter paper in the CHM® quantitative range together with F2045.

It is particularly suitable for analytical procedures and tests involving large particles or gelatinous precipitates (e.g. metal hydroxides and sulphides).

It is also used in metal (Pb) tests in water testing analysis, quantitative air pollution analysis, food industry, paper industry, etc.

F2043 GRADE - Medium filtration

Ashless filter paper with medium filtration speed and good retention (between Grade F2040 and Grade F2041) of medium and thick particles.

Suitable for gravimetric measurements of gypsum/lime suspensions in power plants.

F2043 Grade is particularly applied in metallurgical industry laboratories for metal tests. Typical applications include foodstuffs analysis, soil analysis, particle collection in air pollution monitoring, COD and TOC determination, inorganic analysis in the construction, mining and steel industries. They are also used for Blaine test in the cement industry (standards UNE 80-112-91 and EN 196-6), and to carry out other chemical analysis on cement.

F2040 GRADE – Medium-slow filtration

The classic general purpose ashless filter paper with a medium-to-slow filtering rate.

Suitable for typical applications which includes gravimetric analysis for numerous components and for all kind of pre-filtrations.

Used as a primary filter for separating solid matter from aqueous extracts, in tests for fat and oil in water, in general soil analysis, quantitative determination of sediments in milk, as well as in analytical grade clean-up filter for solutions prior to AA spectro-photometry. Suitable for finer precipitates such as hot barium sulphate.

F2044 GRADE – Slow filtration

A thinner version of F2042 Grade but with a higher flow rate (twice as fast as F2042 Grade).

Very fine particles but with lower ash weight per sample

F2042 GRADE – Very slow filtration







An ashless world standard filter for critical gravimetric analysis. With slow filtering rate and fine particle retention.

Typical analytical precipitates such as cold barium sulphate, lead sulphate, zinc and nickel sulphides, etc.

Grade Applications

F2045	Filtration of coarse and voluminous precipitates such as iron hydroxide, aluminium hydroxide and chromium hydroxide Silica content determinations in steel and iron Food and beverage analysis
F2041	Food analysis Soil analysis Determination of metals in water Filtration of lead sulphide, iron sulphide, silver sulphide and alkali carbonates Blaine test in the cement industry (standards UNE 80-112-91 and EN 196-6)
F2043	Filtration of medium size particles Precipitates such as calcium oxalate, magnesium ammonium phosphate, and barium sulphate Blaine test in the cement industry (standards UNE 80-112-91 and EN 196-6)
F2040	Fine precipitates CaC_2O_4 , PbSO_4 , BaSO_4 (precipitates)
F2044	Filtration of fine precipitates such as barium sulphate and cuprous oxide Soil analysis: measurement of soluble sulphates
F2042	Critical analytical filtration conditions Fine precipitates Precipitates such as cold barium sulphate, lead sulphate, zinc and nickel sulphides, etc

Technical Specifications

Grade	Filtration Speed	Weight (g/m ²)	Thickness (μm)	Retention Range (μm)	Ash Content (%)
 F2045	Very Fast	85	210	25-30	<0.007
 F2041	Fast	85	190	20-25	<0.007
 F2043	Medium	85	180	14-17	<0.007
 F2040	Medium-Slow	85	170	7-9	<0.007
 F2044	Slow	85	160	2-4	<0.007
 F2042	Very Slow	100	160	2-3	<0.007



Order Information

Diameter (mm)	F2045	F2041	F2043	F2040	F2044	F2042
1000 Circles/Box						
12.5	F2045-012.5	F2041-012.5	F2043-012.5	F2040-012.5	F2044-012.5	F2042-012.5
12.7	F2045-012.7	F2041-012.7	F2043-012.7	F2040-012.7	F2044-012.7	F2042-012.7
12.8	F2045-012.8	F2041-012.8	F2043-012.8	F2040-012.8	F2044-012.8	F2042-012.8
25	F2045-025	F2041-025	F2043-025	F2040-025	F2044-025	F2042-025
100 Circles/Box						
37	F2045-037	F2041-037	F2043-037	F2040-037	F2044-037	F2042-037
40.5	F2045-040	F2041-040	F2043-040	F2040-040	F2044-040	F2042-040
42.5	F2045-042	F2041-042	F2043-042	F2040-042	F2044-042	F2042-042
47	F2045-047	F2041-047	F2043-047	F2040-047	F2044-047	F2042-047
50	F2045-050	F2041-050	F2043-050	F2040-050	F2044-050	F2042-050
55	F2045-055	F2041-055	F2043-055	F2040-055	F2044-055	F2042-055
70	F2045-070	F2041-070	F2043-070	F2040-070	F2044-070	F2042-070
80	F2045-080	F2041-080	F2043-080	F2040-080	F2044-080	F2042-080
90	F2045-090	F2041-090	F2043-090	F2040-090	F2044-090	F2042-090
100	F2045-100	F2041-100	F2043-100	F2040-100	F2044-100	F2042-100
110	F2045-110	F2041-110	F2043-110	F2040-110	F2044-110	F2042-110
125	F2045-125	F2041-125	F2043-125	F2040-125	F2044-125	F2042-125
150	F2045-150	F2041-150	F2043-150	F2040-150	F2044-150	F2042-150
185	F2045-185	F2041-185	F2043-185	F2040-185	F2044-185	F2042-185
200	F2045-200	F2041-200	F2043-200	F2040-200	F2044-200	F2042-200
240	F2045-240	F2041-240	F2043-240	F2040-240	F2044-240	F2042-240
250	F2045-250	F2041-250	F2043-250	F2040-250	F2044-250	F2042-250
270	F2045-270	F2041-270	F2043-270	F2040-270	F2044-270	F2042-270
320	F2045-320	F2041-320	F2043-320	F2040-320	F2044-320	F2042-320
Size (mm)	F2045	F2041	F2043	F2040	F2044	F2042
100 Sheets/Pack						
203x254	F2045-203254	F2041-203254	F2043-203254	F2040-203254	F2044-203254	F2042-203254
460x570	F2045-460570	F2041-460570	F2043-460570	F2040-460570	F2044-460570	F2042-460570
580x580	F2045-580580	F2041-580580	F2043-580580	F2040-580580	F2044-580580	F2042-580580

(*) Add an F at the end of the reference for folded circles (e.g. F2040-150F). Other sizes and packaging are available under request.

Equivalence Table

CHMLAB	Filtration Speed	WHATMAN	S&S	M&N	SARTORIUS
F2045	Very fast	-	589/1	640we	388
F2041	Fast	41	589/2	640w	389
F2043	Medium	43	589/5	640m	392
F2040	Medium-slow	40	589/6	640md	390
F2044	Slow	44	589/3	640d	391
F2042	Very slow	42	-	640de	393

1.1.2 Ashless hardened filter paper for quantitative analysis

Ashless hardened Filter papers are acid hardened which reduce the ash content to an extremely low level.

These filters are produced by a complex elaborate washing process under stringently controlled conditions. Firstly, acid washing is arranged. Then a series of washes in demineralised water come, which increase the strength of the paper, therefore making them particularly suitable for Büchner filter funnels and a wide range of critical analytical filtration operations.

Through this process, a maximum ash content of <0.006% is attained, which means that no contaminants are introduced when filtering. Also, full compliance with international standards on this subject is achieved.

Thanks to the hardened texture, they are often used when the analyst must recover the precipitates retained on the filter surface.

F2141 GRADE - Fast filtration

Hardened ashless filter paper with a fast flow rate. Preferably used for the filtration of coarse flocculent and bulky precipitates (as aluminium, chromium or hydroxides of iron, bismuth, cobalt, sulphides of copper, various organic metal precipitates, etc.) and gelatinous precipitates in acid/alkaline solutions during gravimetric analysis.

F2140 GRADE – Medium filtration

Hardened ashless filter paper with medium retention and flow rate.

Extremely strong and pure. With a hard surface, it is recommended for filtering medium-sized precipitates such as most metal sulphides.

High chemical resistance. Used in the gravimetric analysis of metals in acid and slightly alkalized solutions, pressure filtration.

F2142 GRADE - Slow filtration

Hardened ashless filter paper with high retention and slow flow rate.

High chemical resistance. Often used for filtering very fine precipitates and in gravimetric metal determinations.

Grade	Applications
F2141	Food analysis Fibre detection in pet food Filtration of coarse flocculent and bulky precipitates (as aluminium, chromium or hydroxides of iron, bismuth, cobalt, sulphides of copper, various organic metal precipitates, etc.) Gravimetric analysis of gelatinous precipitates in acid/alkaline solutions
F2140	Filtration of fine crystalline precipitates Gravimetric analysis of metals in acid/alkaline solutions
F2142	Filtration of very fine precipitates Gravimetric metal determinations

Technical Specifications

Grade	Filtration Speed	Weight (g/m ²)	Thickness (μm)	Retention Range (μm)	Ash Content (%)
F2141	Fast	84	170	20-25	<0.006
F2140	Medium	84	160	7-12	<0.006
F2142	Slow	95	150	2-4	<0.006

Order Information

Diameter (mm)	F2141	F2140	F2142
1000 Circles/Box			
25	F2141-025	F2140-025	F2142-025
100 Circles/Box			
40.5	F2141-040	F2140-040	F2142-040
42.5	F2141-042	F2140-042	F2142-042
47	F2141-047	F2140-047	F2142-047
50	F2141-050	F2140-050	F2142-050
55	F2141-055	F2140-055	F2142-055
70	F2141-070	F2140-070	F2142-070
80	F2141-080	F2140-080	F2142-080
90	F2141-090	F2140-090	F2142-090
100	F2141-100	F2140-100	F2142-100
110	F2141-110	F2140-110	F2142-110
125	F2141-125	F2140-125	F2142-125
150	F2141-150	F2140-150	F2142-150
185	F2141-185	F2140-185	F2142-185
200	F2141-200	F2140-200	F2142-200
240	F2141-240	F2140-240	F2142-240
250	F2141-250	F2140-250	F2142-250
270	F2141-270	F2140-270	F2142-270
320	F2141-320	F2140-320	F2142-320
Size (mm)	F2141	F2140	F2142
100 Sheets/Pack			
203x254	F2141-203254	F2140-203254	F2142-203254
460x570	F2141-460570	F2140-460570	F2142-460570
580x580	F2141-580580	F2140-580580	F2142-580580

(*) Add an F at the end of the reference for folded circles (e.g. F2140-150F). Other sizes and packaging are available under request.

Equivalence Table

CHMLAB	Filtration Speed	WHATMAN	S&S	M&N	SARTORIUS
F2141	Fast	541	1505	1640w	1388
F2140	Medium	540	1506	1640m	1392
F2142	Slow	542	1507	1640de	1391

1.1.3 Hardened low ash filter paper for quantitative analysis

These filters, made from cotton linters fiber, are put through a washing process and treated with strong acids. Then they are washed in demineralised water to produce high wet strength (appropriate for filtering in high pressure or vacuum conditions) and chemical resistance (suitable to work with acids or alkaline solutions in moderate concentrations).

A very low ash-content filter with a <0.015% (the maximum ash contents of these filters is intermediate between CHM® qualitative grades and ashless quantitative grades).

A very smooth surface makes easy to recover the whole precipitate after the filtration which is particularly indicated for Büchner filtrations.

F2054 GRADE - Fast filtration

The fastest filter paper in the range.

Suitable for filtering coarse, gelatinous or dense liquids. Good load capacity.

F2052 GRADE - Medium-fast filtration

General-purpose hardened filter paper with medium-rate filtering, with good retention of medium particles, such as calcium oxalate and metal sulphides.

Suitable for various tests on the intake of atmospheric pollution (sulphur oxides, ammonia gases, etc) as well as for microbiological water analysis.

They are used in fat extraction equipments as well as in the oilseed and food industries, and a large number of routine analytic procedures.

F2050 GRADE - Slow filtration

CHM® filter with slow filtering rate, with excellent retention of very fine particles, such as barium sulphate, zinc sulphide, etc.

A hardened and glazed surface makes this paper suitable for use in the electronic industry in carriers of electronic components or boards.

Grade	Applications
-------	--------------

F2054	Filtration for coarse, gelatinous or dense precipitates
-------	---

F2052	Determination of atmospheric pollution (sulphur oxide, ammonia gases, etc) General-purpose filtration for quantitative analysis
-------	--

F2050	Filtration of very fine precipitates such as barium sulphate and zinc sulphate Vacuum filtration for quantitative and qualitative analysis
-------	---

Technical Specifications

Grade	Filtration Speed	Weight (g/m ²)	Thickness (μm)	Retention Range (μm)	Ash Content (%)
F2054	Fast	90	200	20-25	<0.015
F2052	Medium-Fast	90	190	7-8	<0.015
F2050	Slow	90	180	2-3	<0.015

Order Information

Diameter (mm)	F2054	F2052	F2050
1000 Circles/Box			
25	F2054-025	F2052-025	F2050-025
100 Circles/Box			
40.5	F2054-040	F2052-040	F2050-040
42.5	F2054-042	F2052-042	F2050-042
47	F2054-047	F2052-047	F2050-047
50	F2054-050	F2052-050	F2050-050
55	F2054-055	F2052-055	F2050-055
70	F2054-070	F2052-070	F2050-070
80	F2054-080	F2052-080	F2050-080
90	F2054-090	F2052-090	F2050-090
100	F2054-100	F2052-100	F2050-100
110	F2054-110	F2052-110	F2050-110
125	F2054-125	F2052-125	F2050-125
150	F2054-150	F2052-150	F2050-150
185	F2054-185	F2052-185	F2050-185
200	F2054-200	F2052-200	F2050-200
240	F2054-240	F2052-240	F2050-240
250	F2054-250	F2052-250	F2050-250
270	F2054-270	F2052-270	F2050-270
320	F2054-320	F2052-320	F2050-320
Size (mm)	F2054	F2052	F2050
100 Sheets/Pack			
203x254	F2054-203254	F2052-203254	F2050-203254
460x570	F2054-460570	F2052-460570	F2050-460570
580x580	F2054-580580	F2052-580580	F2050-580580

(*) Add an F at the end of the reference for folded circles (e.g. F2050-150F). Other sizes and packaging are available under request.

Equivalence Table

CHMLAB	Filtration Speed	WHATMAN	S&S
F2054	Fast	54	1573
F2052	Medium-fast	52	1574
F2050	Slow	50	1575

1.2 Qualitative filter paper

1.2.1 Ashless hardened filter paper for qualitative analysis

These filter papers are used for qualitative analysis.

Qualitative filters are made of refined pulp and pure cotton linters with an alpha-cellulose content of nearly 100%, which gives them a number of diverse filtration properties.

The ash content of less than 0,06% is not reduced by post-treatment.

Qualitative filter papers are available in sheets, discs and folded filters.

F1004 GRADE - Very fast filtration

Very high rate of filtration with excellent retention of coarse precipitates such as metal hydroxides and sulphides or gelatinous substances.

Preferably used as rapid filter for various organic metal precipitates, routine cleanup of biological fluids, food industry analysis, air pollution monitoring (high rates and the fine particles collection is not critical).

F1007 GRADE - Fast filtration

A standard grade filter used for a wide variety of analytical routine applications in different industries. These cellulose filters are used in qualitative analytical techniques to determine and identify materials. Pre-pleated qualitative filters are also available, which give improved flow rate and increased loading capacity compared to equivalent flat filters.

F1001 GRADE - Medium filtration

The most widely used filter paper in the CHM® range.

Medium retention and flow rate. This grade covers a wide range of laboratory applications and is frequently used for clarifying liquids. Traditionally this grade is used in qualitative analytical separations for routine laboratory work as well as rapid filtration of fine precipitates such as lead sulphate, calcium oxalate (hot) and calcium carbonate.

In agriculture, it is used for soil analysis and seed testing procedures.

In the food industry, Grade F1001 is used for numerous routine techniques to separate solid foodstuffs from associated liquid or extracting liquid.

It is widely used in education for teaching simple qualitative analytical separations.

In air pollution monitoring, using circles or rolls, atmospheric dust is collected from airflow and the stain-intensity measured photometrically.

For gas detection, the paper is impregnated with a chromogenic reagent and colour formation quantified by optical reflectance.

F1002 GRADE - Medium-slow filtration

Slightly more retentive and absorbent than Grade F1001 and therefore with a moderate to slow filtration speed.

In addition to general filtration this grade F1002 is used for monitoring specific contaminants in the atmosphere, filtration of fine precipitates, soil testing, it is often used as a folded filter in an analytical funnel.

F1003 GRADE - Medium-slow filtration (thick)

Medium to low rate of filtration with double the thickness comparing with CHM® Grade F1001.

Fine particle retention and excellent loading capacity.

The extra thickness gives increased wet strength and allows a higher solute loading.

Preferably used for liquids hard to clarify, essences, oils, tinctures, particularly useful for use in Büchner-funnels.

F1006 GRADE - Slow filtration

Similar particle retention as Grade F1005 with higher filtration speed.

Often used for boiler water analysis.

F1005 GRADE - Very slow filtration

Lowest rate of filtration in the CHM® qualitative range and maximum degree of fine particle filtration or retention.

Preferably used as a clarifying filter for cloudy suspensions and water and soil analysis. Particularly used in difficult filtration conditions and extra fine-grained precipitates such as barium sulphate, cupreous oxide, often specified for clarification of wine.



Grade Applications

F1004	Coarse and gelatinous precipitates such as iron hydroxide, aluminium hydroxide and chromium hydroxide Silica determination in steel and iron analysis Food analysis Monitoring of air pollution when the collection of fine particles is not critical Routine clean-up of biological fluids or organic extracts
F1007	Filtration of a wide range of routine laboratory applications Food analysis. Determination of fat content Beverage analysis. Removal of carbon dioxide and turbidity from beer and other beverages
F1001	Filtration of a wide range of routine laboratory applications for medium retention Filtration of fine precipitates such as lead sulphate, calcium oxalate, calcium carbonate and other metal sulphates Soil analysis and seed testing Food analysis Education Used in the beer and malt control quality production according to EBC.
F1002	Monitoring specific contaminants in the atmosphere Filtration of fine precipitates such as lead dioxide, calcium fluoride, nickel sulphide and zinc sulphide Soil analysis
F1003	Particularly useful for use in Büchner funnels Preferably used for liquids hard to clarify, essences, oils and tinctures
F1006	Filtration of very fine crystalline precipitates Beverage analysis. Sample preparation and removal of carbon dioxide for beverages Monitoring specific contaminants in the atmosphere Soil analysis
F1005	Filtration in very difficult conditions Filtration for extra fine-grained precipitates such as barium sulphate, cupreous oxide often specified used for clarification of wine

Technical Specifications

Grade	Filtration Speed	Weight (g/m ²)	Thickness (µm)	Retention Range (µm)	Ash Content (%)
F1004	Very fast	84	190-230	12-15	<0.06
F1007	Fast	84	190-230	8-12	<0.06
F1001	Medium	84	160-190	7-11	<0.06
F1002	Medium-Slow	97	190	5-8	<0.06
F1003	Medium-Slow/Thick	200	320	5-7	<0.06
F1006	Slow	84	140-160	3-5	<0.06
F1005	Very Slow	80	170	1-2	<0.06

Order Information

Diameter (mm)	F1004	F1007	F1001	F1002	F1003	F1006	F1005
1000 Circles/Box							
25	F1004-025	F1007-025	F1001-025	F1002-025	F1003-025	F1006-025	F1005-025
100 Circles/Box							
37	F1004-037	F1007-037	F1001-037	F1002-037	F1003-037	F1006-037	F1005-037
40.5	F1004-040	F1007-040	F1001-040	F1002-040	F1003-040	F1006-040	F1005-040
42.5	F1004-042	F1007-042	F1001-042	F1002-042	F1003-042	F1006-042	F1005-042
47	F1004-047	F1007-047	F1001-047	F1002-047	F1003-047	F1006-047	F1005-047
50	F1004-050	F1007-050	F1001-050	F1002-050	F1003-050	F1006-050	F1005-050
55	F1004-055	F1007-055	F1001-055	F1002-055	F1003-055	F1006-055	F1005-055
70	F1004-070	F1007-070	F1001-070	F1002-070	F1003-070	F1006-070	F1005-070
80	F1004-080	F1007-080	F1001-080	F1002-080	F1003-080	F1006-080	F1005-080
90	F1004-090	F1007-090	F1001-090	F1002-090	F1003-090	F1006-090	F1005-090
100	F1004-100	F1007-100	F1001-100	F1002-100	F1003-100	F1006-100	F1005-100
110	F1004-110	F1007-110	F1001-110	F1002-110	F1003-110	F1006-110	F1005-110
125	F1004-125	F1007-125	F1001-125	F1002-125	F1003-125	F1006-125	F1005-125
150	F1004-150	F1007-150	F1001-150	F1002-150	F1003-150	F1006-150	F1005-150
185	F1004-185	F1007-185	F1001-185	F1002-185	F1003-185	F1006-185	F1005-185
200	F1004-200	F1007-200	F1001-200	F1002-200	F1003-200	F1006-200	F1005-200
240	F1004-240	F1007-240	F1001-240	F1002-240	F1003-240	F1006-240	F1005-240
250	F1004-250	F1007-250	F1001-250	F1002-250	F1003-250	F1006-250	F1005-250
270	F1004-270	F1007-270	F1001-270	F1002-270	F1003-270	F1006-270	F1005-270
320	F1004-320	F1007-320	F1001-320	F1002-320	F1003-320	F1006-320	F1005-320
Size (mm)	F1004	F1007	F1001	F1002	F1003	F1006	F1005
100 Sheets/Pack							
460x570	F1004-460570	F1007-460570	F1001-460570	F1002-460570	F1003-460570	F1006-460570	F1005-460570
580x580	F1004-580580	F1007-580580	F1001-580580	F1002-580580	F1003-580580	F1006-580580	F1005-580580

(*) Add an F at the end of the reference for folded circles (e.g. F1001-150F). Other sizes and packaging are available under request.

Equivalence Table

CHMLAB	Filtration Speed	WHATMAN	S&S	M&N	SARTORIUS
F1004	Very fast	4	604	1670/617	288
F1007	Fast	-	597	-	289
F1001	Medium	1	593/595	616/615	292
F1002	Medium-slow	2	-	616md	292a
F1003	Medium/thick	3	591	618	3 S/h
F1006	Slow	6	602h	619eh	290
F1005	Very slow	5	602eh	619de	293

1.2.2 General-purpose qualitative filter paper

These general-purpose filters have a high wet strengthened. They are made of high-purity cotton linters and other virgin fibers. These filter papers have either fast or very fast filtration rates, and are particularly useful in filtering coarse precipitates or relatively straightforward substances.

These filters are not recommended for Kjeldahl estimations. The recommended grades are F7512 and E4002.

F1093 GRADE - Very fast filtration

Smooth Grade F1093 is a general-purpose filter paper for qualitative analysis.

This wet strengthened paper is used for general filtration and sample preparation for food, sugar processing plants, hospitals, educational and research centres, colleges, universities and labs (with a very high usage and less critical analysis), etc.

F1094 GRADE - Very fast filtration

General-purpose filter paper, smooth and similar to F1093 with less weight.

F1113 GRADE - Extra-fast filtration. Thick

High particle retention and extremely high loading capacity.

Preferably used for filtration of gelatine, resin solutions and other viscous liquids, such as syrups, oils, essences and fats.

The folded format enables bigger volumes to be dealt at atmospheric pressures.

F1091 GRADE - Very fast filtration. Crêped

Crêped surface filter paper with a very fast flow rate.

For general laboratory use in less-critical analyses.

Used around the world in laboratories to assay sugar cane or beet. The fruit is mashed and further analyzed according to the aluminium sulphur method.

F1096 GRADE - Medium-fast filtration

Smooth and thick filter paper, medium-fast filtration. Filtrates viscous liquids, essences, syrups and dense oils. Filtration with high load of precipitates.

F1095 GRADE - Fast. Crêped

General-purpose filter paper, which filtrates with high particle load. Used for the determination of sucrose content in the sugar industry.

Grade	Applications
F1093	General filtration and sample preparation in different kind of laboratories General filtration and sample preparation in food and sugar processing plants
F1094	General-purpose filtration
F1113	Filtration of gelatines, resin solutions and other viscous liquids such as syrups, dense oils, essences and fats
F1091	Determination of sucrose in the sugar cane or beet
F1096	Filtration of fine-medium particles
F1095	Determination of sucrose content in the sugar industry

Technical Specifications

Grade	Filtration Speed	Weight (g/m ²)	Thickness (μm)	Retention Range (μm)	Ash Content (%)
F1093	Very Fast	80	170	43-48	<0.1
F1094	Very Fast	65	145	6-9	<0.1
F1113	Extra-Fast/Thick	160	470	60-68	<0.1
F1091	Very Fast/Crêped	65	160	34-42	<0.1
F1096	Medium-Fast	85	180	14-22	<0.1
F1095	Fast/Crêped	90	330	26-34	<0.1

Order Information

Diameter (mm)	F1093	F1094	F1113	F1091	F1096	F1095
1000 Circles/Box						
25	F1093-025	F1094-025	F1113-025	F1091-025	F1096-025	F1095-025
100 Circles/Box						
40.5	F1093-040	F1094-040	F1113-040	F1091-040	F1096-040	F1095-040
42.5	F1093-042	F1094-042	F1113-042	F1091-042	F1096-042	F1095-042
47	F1093-047	F1094-047	F1113-047	F1091-047	F1096-047	F1095-047
50	F1093-050	F1094-050	F1113-050	F1091-050	F1096-050	F1095-050
55	F1093-055	F1094-055	F1113-055	F1091-055	F1096-055	F1095-055
70	F1093-070	F1094-070	F1113-070	F1091-070	F1096-070	F1095-070
80	F1093-080	F1094-080	F1113-080	F1091-080	F1096-080	F1095-080
90	F1093-090	F1094-090	F1113-090	F1091-090	F1096-090	F1095-090
100	F1093-100	F1094-100	F1113-100	F1091-100	F1096-100	F1095-100
110	F1093-110	F1094-110	F1113-110	F1091-110	F1096-110	F1095-110
125	F1093-125	F1094-125	F1113-125	F1091-125	F1096-125	F1095-125
130	F1093-130	F1094-130	F1113-130	F1091-130	F1096-130	F1095-130
150	F1093-150	F1094-150	F1113-150	F1091-150	F1096-150	F1095-150
185	F1093-185	F1094-185	F1113-185	F1091-185	F1096-185	F1095-185
200	F1093-200	F1094-200	F1113-200	F1091-200	F1096-200	F1095-200
240	F1093-240	F1094-240	F1113-240	F1091-240	F1096-240	F1095-240
250	F1093-250	F1094-250	F1113-250	F1091-250	F1096-250	F1095-250
270	F1093-270	F1094-270	F1113-270	F1091-270	F1096-270	F1095-270
300	F1093-300	F1094-300	F1113-300	F1091-300	F1096-300	F1095-300
320	F1093-320	F1094-320	F1113-320	F1091-320	F1096-320	F1095-320
350	F1093-350	F1094-350	F1113-350	F1091-350	F1096-350	F1095-350
400	F1093-400	F1094-400	F1113-400	F1091-400	F1096-400	F1095-400
450	F1093-450	F1094-450	F1113-450	F1091-450	F1096-450	F1095-450
500	F1093-500	F1094-500	F1113-500	F1091-500	F1096-500	F1095-500
650	F1093-650	F1094-650	F1113-650	F1091-650	F1096-650	F1095-650

Order Information

Size (*) (mm)	F1093	F1094	F1113	F1091	F1096	F1095
100 Sheets/Pack						
460x570	F1093-460570	F1094-460570	F1113-460570	F1091-460570	F1096-460570	F1095-460570
580x580	F1093-580580	F1094-580580	F1113-580580	F1091-580580	F1096-580580	F1095-580580

(*) Add an F at the end of the reference for folded circles (e.g. F1093-150F). Other sizes and packaging are available under request.

Equivalence Table

CHMLAB	Filtration Speed	WHATMAN	S&S	M&N	SARTORIUS
F1093	Very fast	93	860	617	4b
F1094	Very fast	-	-	-	3m/N
F1113	Extra-fast/Thick	-	3144L	-	-
F1091	Very fast/Crêped	91	0856	-	601/N
F1096	Medium-fast	-	-	-	-
F1095	Fast/Crêped	-	-	-	33/N



1.3 Special filter papers

1.3.1 Activated carbon paper

F1010 grade activated carbon filter paper is used to eliminate or adsorb small molecules in large amounts as benzene, toluene, ethyl-benzene, xylene and organic compounds. Recommended for water filtration and smell elimination.

Applications

Decoloration of samples

Absorption of radioactive ions in the atmosphere

Determination of the content of sugar in the urine by polarimetric method

Technical Specifications

Grade	Carbon (%)	Weight (g/m ²)	Thickness (μm)
F1010	40	155	500

Order Information

Diameter (mm)	Order Number	Quantity/Box
70	F1010-070	100
90	F1010-090	100
100	F1010-100	100
130	F1010-130	100
150	F1010-150	100
200	F1010-200	100
250	F1010-250	100
300	F1010-300	100
350	F1010-350	100
400	F1010-400	100
450	F1010-450	100
500	F1010-500	100



1.3.2. Filter paper with diatomaceous

Filter paper with low filtration speed. Made with a mixture of cellulose fibers and diatomaceous soils (diatomaceous algae), the main property is its microporous structure, up to 0.5 μm . The land production process begins with open pit mining. Subsequently, a drying phase follows and it is subjected to high temperatures to eliminate any remaining residue. Finally, it is crushed for industrial use.

This filter paper combines excellent retention of very fine or semi-colloidal particles with a faster filtration speed than any slow filtration cellulose filter paper.

Applications

Filtration of samples for spectrophotometric analysis

Clay samples

Separation of samples with Cu oxides

Protein samples

Technical Specifications

Grade	Filtration Speed	Weight (g/m^2)	Thickness (μm)
F7660	Slow	140	320

Order Information

Diameter (mm)	Order Number	Quantity/Box
90	F7660-090	100
110	F7660-110	100
125	F7660-125	100
150	F7660-150	100
185	F7660-185	100
240	F7660-240	100
270	F7660-270	100
400	F7660-400	100
500	F7660-500	100

Equivalence Table

CHMLAB	Filtration Speed	S&S	M&N
F7660	Slow	287	MN660

1.3.3. Filter paper free of K and P, low of N

A very pure filter paper with medium filtration speed. Exempt of phosphates and potassium, and low on the content of nitrogen. Special for analysis of soils according to Ehmer, Riehm and Lederle, determination of phosphates and nitrates in minerals and the analysis of the components of nitrogen in products like beer and other specific assays Kjeldahl before the digestion.

Applications

Determination of phosphates and nitrate in floor samples according to Ehmer, Riehm and Lederle

Analysis of the nitrogen components in beer samples

Filtration of samples before digestion according to the Kjeldahl method

Quality analysis for miner explosions

Technical Specifications

Grade	Filtration Speed	Weight (g/m ²)	Retention Range (µm)
F7512	Medium	85	15-17

Order Information

Diameter (mm)	Order Number		Quantity/Box
	Plane	Folded	
47	F7512-047	-	100
50	F7512-050	-	100
55	F7512-055	-	100
70	F7512-070	F7512-070F	100
90	F7512-090	F7512-090F	100
110	F7512-110	F7512-110F	100
125	F7512-125	F7512-125F	100
150	F7512-150	F7512-150F	100
185	F7512-185	F7512-185F	100
200	F7512-200	F7512-200F	100
240	F7512-240	F7512-240F	100
270	F7512-270	F7512-270F	100
320	F7512-320	F7512-320F	100

Equivalence Table

CHMLAB	Filtration Speed	S&S	M&N	SARTORIUS
F7512	Medium	512	MN616G	132

1.3.4. Black filter paper

A filter paper tinted in black, specially indicated for the retention and later visualization of light colored particles, by contrast. For example, with some fluorine compounds and silicones.

Applications

Determination of the content of lumps in industrial and food products

Visualization, by contrast, of light colored particles

Solid particle count in milk powder samples

Technical Specifications

Grade	Filtration Speed	Weight (g/m ²)	Thickness (μm)
F7551	Medium	85	170

Order Information

Diameter (mm)	Order Number	Quantity/Box
55	F7551-055	100
70	F7551-070	100
90	F7551-090	100
110	F7551-110	100
125	F7551-125	100
150	F7551-150	100
185	F7551-185	100
200	F7551-200	100
240	F7551-240	100
270	F7551-270	100
320	F7551-320	100

Equivalence Table

CHMLAB	Filtration Speed	WHATMAN	S&S	M&N
F7551	Medium	551	551	MN220

1.3.5. Filter paper for fat analysis

A filter paper made from high purity cellulose fibers. Subsequently, it is treated with organic solvents that guarantee a minimum fat content and soluble residue with ether <0.1 mg for a circle with 270 mm diameter filter.

Applications

Critical analysis of the fat content in all type of substances

Technical Specifications

Grade	Filtration Speed	Weight (g/m ²)	Thickness (μm)
F7615	Medium	70	160

Order Information

Diameter (mm)	Order Number		Quantity/Box
	Plane	Folded	
47	F7615-047	-	100
50	F7615-050	-	100
55	F7615-055	-	100
70	F7615-070	F7615-070F	100
90	F7615-090	F7615-090F	100
110	F7615-110	F7615-110F	100
125	F7615-125	F7615-125F	100
150	F7615-150	F7615-150F	100
185	F7615-185	F7615-185F	100
200	F7615-200	F7615-200F	100
240	F7615-240	F7615-240F	100
270	F7615-270	F7615-270F	100
320	F7615-320	F7615-320F	100

Equivalence Table

CHMLAB	Filtration Speed	M&N
F7615	Medium	MN615ff

1.4 Glass microfiber filters

CHMLAB offers a wide range of glass microfiber filters made of 100% borosilicate glass fibers with and without binders. The depth structure of the filter's large surface area, provides an outstanding impurity retention capacity combined with a low filter resistance.

Glass fiber filters adsorb the finest particles down to 1 μm from liquids and $<1 \mu\text{m}$ in air and gases (even aerosols with this particle diameter are separated), as the electrostatic interaction between the glass fibers and gases is better than between glass fibers and liquids.

Temperature resistant up to 500°C (in the case of organic binders up to 180°C).

1.4.1 Glass microfiber filters without binders

GF1 GRADE (1.6 μm)

Particularly suited for atmospheric pollution controls, intake controls and ozone level measurements.

This product is used in testing with algae in water, for general water controls and waste water analysis.

Its use for filtering solvents in high-resolution laboratories is recommended.

GF2 GRADE (1.0 μm)

It is mainly used in membrane pre-filtration and for biochemical assays.

Suitable for filtration of large sample volumes.

GF3 GRADE (1.2 μm)

This is the most suitable filter to test for solids in suspension in water in accordance with the parameters set by the EN-872:2005 European regulation and American Standard Methods norm 2540D. In general, it is suitable for any work in water control or wastewater analysis, including clarification processes.

Within biochemical tests, it is very useful for analysing carbohydrates, cellular cultures, etc.

GF4 GRADE (2.7 μm)

The most widespread use of this filter is in membrane pre-filtering.

Its high particle retention ensures that the sample is properly clarified before passing through surface filters (membrane filters).

GF5 GRADE (0.7 μm)

This is the filter with the highest retention performance of the range. It is particularly suited to filter samples and solvents for HPLC, being this pre-filtration the most important for ensuring the success of the test. It is also suitable for biochemical tests, such as clarifications, protein filtrations, cellular cultures, etc.

GF6 GRADE (1.5 μm)

Suitable for atmospheric pollution control, particularly in testing for air intake levels. It is also appropriate for wastewater controls, testing for solids in suspension, dissolved solids and volatile matter in accordance with the parameters set by the American Standard Methods norm 2540D.

It is also suitable for cellular cultures.

Grade Applications

GF1	Atmospheric pollution controls, intake controls and ozone level measurements Filtration for algae in water, foodstuff analysis, bacteria cultures, proteins
GF2	Used in membrane pre-filtration Biochemical assays Suitable for filtration of large volumes
GF3	Determination of suspended soils in water in accordance with European regulations Clarification and monitoring water and wastewater analysis Analysis of carbohydrates, cellular cultures in biochemical tests where cellulose fiber is an inconvenience
GF4	Used as a membrane pre-filter Determination of contaminants in fats according to LMBG
GF5	Highest retention performance of the range Filtration of samples and solvents prior to HPLC Biochemical assays and clarifications of protein solutions
GF6	Filtration of suspended solids in water, wastewater analysis Total suspended solids analysis Atmospheric pollution control It is also suitable for cellular cultures

Technical Specifications

Grade	Retention Range (μm)	Weight (g/m^2)	Thickness (μm)	Retention Dop (*) (%)	Binder
GF1	1.6	52	260	99.998	NO
GF2	1.0	143	700	99.998	NO
GF3	1.2	53	260	99.998	NO
GF4	2.7	120	530	99.998	NO
GF5	0.7	75	450	99.998	NO
GF6	1.5	65	280	99.998	NO

(*) Retention of a Dyoptil Ophtalate fog with $0.3 \mu\text{m}$ particles



Order Information

Diameter (mm)	GF1	GF2	GF3	GF4	GF5	GF6
100 Circles/Box						
21	GF1-021	GF2-021	GF3-021	GF4-021	GF5-021	GF6-021
25	GF1-025	GF2-025	GF3-025	GF4-025	GF5-025	GF6-025
37	GF1-037	GF2-037	GF3-037	GF4-037	GF5-037	GF6-037
42.5	GF1-042	GF2-042	GF3-042	GF4-042	GF5-042	GF6-042
47	GF1-047	GF2-047	GF3-047	GF4-047	GF5-047	GF6-047
50	GF1-050	GF2-050	GF3-050	GF4-050	GF5-050	GF6-050
55	GF1-055	GF2-055	GF3-055	GF4-055	GF5-055	GF6-055
70	GF1-070	GF2-070	GF3-070	GF4-070	GF5-070	GF6-070
80	GF1-080	GF2-080	GF3-080	GF4-080	GF5-080	GF6-080
90	GF1-090	GF2-090	GF3-090	GF4-090	GF5-090	GF6-090
100	GF1-100	GF2-100	GF3-100	GF4-100	GF5-100	GF6-100
110	GF1-110	GF2-110	GF3-110	GF4-110	GF5-110	GF6-110
125	GF1-125	GF2-125	GF3-125	GF4-125	GF5-125	GF6-125
142	GF1-142	GF2-142	GF3-142	GF4-142	GF5-142	GF6-142
150	GF1-150	GF2-150	GF3-150	GF4-150	GF5-150	GF6-150
185	GF1-185	GF2-185	GF3-185	GF4-185	GF5-185	GF6-185
200	GF1-200	GF2-200	GF3-200	GF4-200	GF5-200	GF6-200
240	GF1-240	GF2-240	GF3-240	GF4-240	GF5-240	GF6-240
270	GF1-270	GF2-270	GF3-270	GF4-270	GF5-270	GF6-270
293	GF1-293	GF2-293	GF3-293	GF4-293	GF5-293	GF6-293
320	GF1-320	GF2-320	GF3-320	GF4-320	GF5-320	GF6-320
Size (mm)	GF1	GF2	GF3	GF4	GF5	GF6
100 Sheets/Pack						
203x254	GF1-203254	GF2-203254	GF3-203254	GF4-203254	GF5-203254	GF6-203254
460x570	GF1-460570	GF2-460570	GF3-460570	GF4-460570	GF5-460570	GF6-460570
580x580	GF1-580580	GF2-580580	GF3-580580	GF4-580580	GF5-580580	GF6-580580

Equivalence Table

CHMLAB	WHATMAN	S&S	M&N	SARTORIUS
GF1	GF-A	GF 50	GF1	MGA
GF2	GF-B	GF 51	GF2	MGB
GF3	GF-C	GF 52	GF3	MCG
GF4	GF-D	GF 53	GF4	MGD
GF5	GF-F	GF 55	GF5	MGF
GF6	934-AH	GF 30	GF6	550-HA

1.4.2 Glass microfiber filters with binders

These glass microfiber filters are mostly used for monitoring air and gas or as prefilter. They have extreme mechanical and chemical stability because they are manufactured with synthetic binders to ensure that the filter has a defined strength. They have a temperature resistance of up to 180°C.

Technical Specifications

Grade	Retention Range (μm)	Weight (g/m^2)	Thickness (μm)	Binder
GB04	0.45	85	450	YES
GB07	0.7	85	450	YES
GB10	1.0	85	450	YES
GB30	3.0	80	420	YES

Grade Applications

GB04	Pre-filtration for Biopharmaceutical and Food & Beverage industry Used as a membrane pre-filter Filtration in ink industry Brine filtration Determination of Chlorophyll and Phytoplankton
GB07	Pre-filtration of samples Water analysis Retention of beer proteins
GB10	Pre-filtration and clarification for Biopharmaceutical and Food & Beverage industry Filtration in ink industry Brine filtration
GB30	Filtration of compressed air aerosols Filtration of jet fuel Brine filtration Filtration of industrial fluids and photographic chemicals Determination of PCB, DBE, DOT, furans and dioxins in the air Determination of powder fractions in the industry

Order Information

Diameter (mm)	GB04	GB07	GB10	GB30
100 Circles/Box				
13	GB04-013	GB07-013	GB10-013	GB30-013
21	GB04-021	GB07-021	GB10-021	GB30-021
25	GB04-025	GB07-025	GB10-025	GB30-025
37	GB04-037	GB07-037	GB10-037	GB30-037
47	GB04-047	GB07-047	GB10-047	GB30-047
50	GB04-050	GB07-050	GB10-050	GB30-050
55	GB04-055	GB07-055	GB10-055	GB30-055
70	GB04-070	GB07-070	GB10-070	GB30-070
80	GB04-080	GB07-080	GB10-080	GB30-080
90	GB04-090	GB07-090	GB10-090	GB30-090
100	GB04-100	GB07-100	GB10-100	GB30-100
110	GB04-110	GB07-110	GB10-110	GB30-110
125	GB04-125	GB07-125	GB10-125	GB30-125
142	GB04-142	GB07-142	GB10-142	GB30-142
150	GB04-150	GB07-150	GB10-150	GB30-150
185	GB04-185	GB07-185	GB10-185	GB30-185
200	GB04-200	GB07-200	GB10-200	GB30-200
240	GB04-240	GB07-240	GB10-240	GB30-240
293	GB04-293	GB07-293	GB10-293	GB30-293

Equivalence Table

CHMLAB	WHATMAN	S&S	M&N	SARTORIUS
GB04	-	-	MN 85/90	-
GB07	GF9	GF9	MN 85/70	13400
GB10	GF6	GF6	-	-
GB30	GF8	GF8	-	-

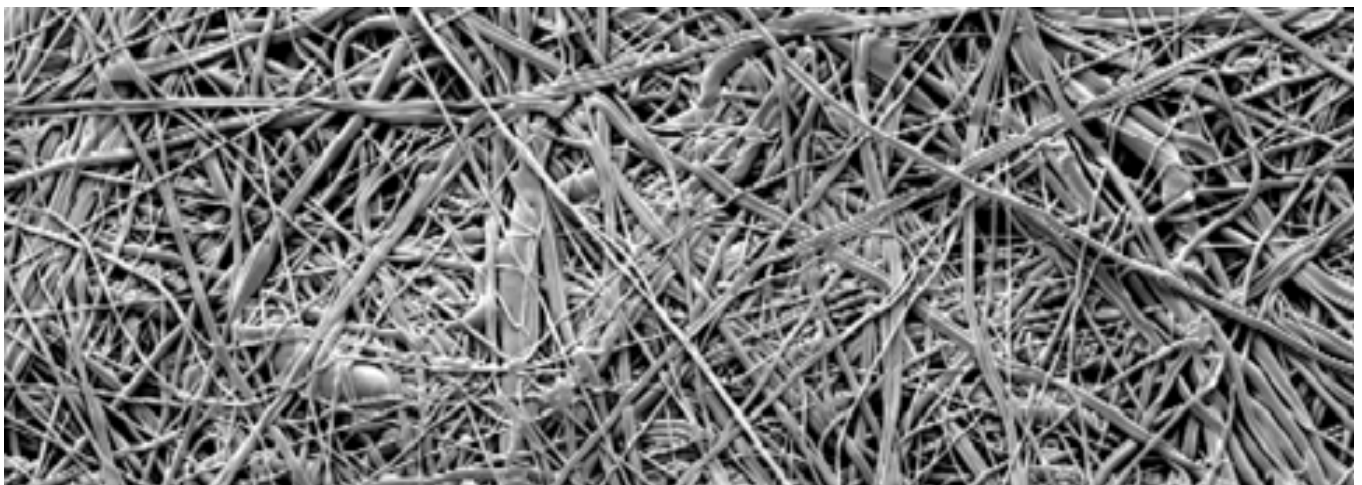

1.5 Quartz microfiber filters

The CHM® quartz microfiber filters are made with pure quartz microfibers and are free of binders or additives of any kind.

These filters have retention, loading and air permeability features similar to those of the glass microfiber filters. However, since they have greater chemical resistance at high temperatures, they can be used in environments where extreme conditions are present, replacing the glass microfiber filters in such cases.

QF1 Standard grade

QF2 Very pure filter/very low trace levels of heavy metals

Features

High-purity quartz microfiber filters (SiO_2) free of binding elements or additives

Excellent retention levels for very fine particles

Very high air permeability

High temperature stability. It is very good up to 900°C , some loss of their usual properties setting in beyond that point

Excellent chemical stability with practically no filter-mass losses through chemical reactions under extreme conditions with the presence of acid gases (HCl , SO_2 , SO_3 , H_2 , SO_4 , NO and NO_3)

Applications

Determination of suspended particles on the atmosphere

Emissions monitoring in industrial chimneys

Gravimetric determination in gases

Monitoring the level of heavy metals in atmospheric pollution studies

Incinerators

When the temperature of emissions is higher than the temperature that the glass microfiber can bear, it is used quartz microfiber

Analysis of acid gases

Microplastic sample preparation and separation before chromatographic analysis



Technical Specifications

Grade	Weight (g/m ²)	Thickness (µm)	Retention Dop (*) (%)	Maximum Temperature (°C)	Binder
QF1	85.0	440	99,998	900	NO
QF2	85.0	430	99,998	900	NO

(*) Retention of a Dyoptil Ophtalate fog with 0.3 µm particles

Order Information

Diameter (mm)	QF1	QF2
25 Circles/Box		
21	QF1-021	-
25	QF1-025	-
37	QF1-037	-
40.5	QF1-040	-
42.5	QF1-042	-
45	QF1-045	QF2-045
47	QF1-047	QF2-047
50	QF1-050	QF2-050
55	QF1-055	QF2-055
70	QF1-070	-
80	QF1-080	-
90	QF1-090	QF2-090
100	QF1-100	-
110	QF1-110	-
125	QF1-125	-
142	QF1-142	-
150	QF1-150	QF2-150
100 Sheets/Pack		
203X254	QF1-203254	QF2-203254
460x570	QF1-460570	QF2-460570
580x580	QF1-580580	QF2-580580

Equivalence Table

CHMLAB	WHATMAN	S&S	M&N	SARTORIUS
QF1	QM-A	QF20	QF10	T293
QF2	-	-	-	MK360

Trace elements in ppm

Element	QF1	QF2	Element	QF1	QF2	Element	QF1	QF2
Al	50	25	Fe	30	20	Pb	0.75	0.3
As	0.75	0.2	Hg	<0.05	<0.025	Sb	1.25	<1
Cd	1.5	<0.02	Mg	25	15	Sn	0.5	<0.5
Co	1	<0.5	Mn	1.25	1	Tl	2.5	1.5
Cr	5	3.5	Na	40	10	V	0.5	<0.5
Cu	1.25	<1	Ni	2	0.5	Zn	5	3

1.6 Extraction thimbles

CHM® extraction thimbles are manufactured in three versions:

- High purity cellulose
- Pure borosilicate glass microfiber
- High purity quartz microfiber

The extraction thimbles are suitable for Soxhlet type, Tecator type or similar devices.

They are located in the extractor body, used to accommodate a sample of solid material to extract certain components out, with the addition of an appropriate solvent.

1.6.1 Cellulose extraction thimbles

CHM® high-quality cellulose extraction thimbles are made from high-alpha cellulose cotton linters with rounded bottom.

Features

Manufactured in high-alpha cellulose cotton linters

Strong mechanical structure and retentivity

Maximum working temperature 120°C

Tolerances according to DIN 12449:

- Internal diameter $+0/-3$ mm
- Thimble height ± 1 mm
- Wall thickness ± 0.5 mm
- Ash content $< 0.1\%$

Applications

Fat extraction in foodstuffs, paints and varnishes

Extraction of polymers

Determination of environmental pollutants

They are usually used in extractors of the "Soxhlet", "Tecator" or similar types, in order to collect solid material from which components must be separated out by dissolving in a suitable solvent

The thimbles size selection should be done carefully to fit extractors correctly. The references sizes are internal diameter and the length in mm (an extra allowance for wall thickness should be added when selecting external diameters)

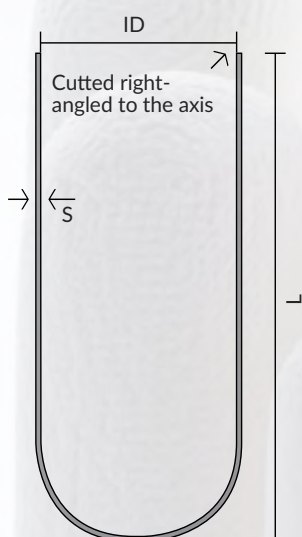

DIMENSIONS OF AN EXTRACTION THIMBLE:

ID = Inner diameter in mm
L = Length in mm
S = Wall thickness in mm

Standard thickness:
F5800 S=1.5 mm
Double thickness:
F5810 $2 < S < 2.5$ mm



Order Information. Standard Thickness (1-1.5 mm)

(*) Size (mm) Int x Length	Order Number	(*) Size (mm) Int x Length	Order Number	(*) Size (mm) Int x Length	Order Number
25 Thimbles/Box		25 Thimbles/Box		25 Thimbles/Box	
10x50	F5800-10050	26x60T ³	F5800-26060T	35x80	F5800-35080
16x100	F5800-16100	27x80	F5800-27080	35x100	F5800-35100
19x90	F5800-19090	27x100	F5800-27100	35x150	F5800-35150
20x80	F5800-20080	28x22 ³	F5800-28022	40x100	F5800-40100
22x60	F5800-22060	28x100	F5800-28100	40x123	F5800-40123
22x65	F5800-22065	30x77	F5800-30077	43x123	F5800-43123
22x80*	F5800-22080	30x80	F5800-30080	48x125	F5800-48125
22x90	F5800-22090	30x100	F5800-30100	50x160	F5800-50160
22x100	F5800-22100	33x80 ²	F5800-33080	52x180	F5800-52180
25x60	F5800-25060	33x94 ¹	F5800-33094	53x145	F5800-53145
25x80	F5800-25080	33x100	F5800-33100	58x180	F5800-58180
25x100	F5800-25100	33x118	F5800-33118	60x80	F5800-60080
26x60	F5800-26060	35x50	F5800-35050	60x120	F5800-60120

(*) Other sizes available under request.

¹ fits Büchi B-811 ² fits Gerhard Soxterm Automatic ³ Foss Tecator Systems, Velp Solvent Extractors fits Foss Soxtec 2050.

Order Information. Double Thickness (2-2.5 mm)

(*) Size (mm) Int x Length	Order Number	(*) Size (mm) Int x Length	Order Number
25 Thimbles/Box		25 Thimbles/Box	
19x90	F5810-19090	33x94	F5810-33094
22x65	F5810-22065	33x100	F5810-33100
22x80	F5810-22080	35x100	F5810-35100
22x90	F5810-22090	60x80	F5810-60080
25x100	F5810-25100	60x120	F5810-60120
28x100	F5810-28100	68x250	F5810-68250
30x100	F5810-30100	75x160	F5810-75160
33x80	F5810-33080	90x180	F5810-90180

(*) Other sizes available under request.

Equivalence Table

CHMLAB	WHATMAN	S&S	M&N	SARTORIUS
F5800	2800	603	MN 645	Grade 30
F5810	2810	-	MN 645 F	-

1.6.2 Glass microfiber thimbles

CHM® high-quality glass microfiber thimbles are made from 100% pure borosilicate fibers. They have special advantages since no binders of any kind are used in their manufacture process.

They are particularly suitable when solvents that are incompatible with cellulose thimbles are present.

Features

Manufactured in 100% pure borosilicate fibers without binders

High loading capacity

High retention of very small particles

High air permeability

Good stability in high temperature. Maximum working temperature 500°C

Tolerances for F5900 glass microfiber thimbles:

- Internal diameter $\pm 1/-3$ mm
- Thimble height ± 1 mm
- Wall thickness 2 ± 0.5 mm

Applications

Extraction of solvents which are not compatible with cellulose cotton linter

Gas emission controls for industrial chimneys

Gravimetric testing for dust in hot gases

Technical Specifications

Grade	Retention Dop (*) (%)	Maximum Temperature (°C)	Binder
F5900	99.998	500	NO

(*) Retention of a Dyoptil Ophtalate fog with 0.3 μ m particles

Order Information

(*) Size (mm) Int x Lenght	Order Number	(*) Size (mm) Int x Lenght	Order Number
25 Thimbles/Box		25 Thimbles/Box	
19x90	F5900-19090	33x80	F5900-33080
22x80	F5900-22080	33x94	F5900-33094
25x80	F5900-25080	33x100	F5900-33100
25x100	F5900-25100	35x150	F5900-35150
26x60	F5900-26060	43x123	F5900-43123
30x80	F5900-30080	52x180	F5900-52180
30x100	F5900-30100	58x180	F5900-58180

(*) Other sizes are available under request.

Equivalence Table

CHMLAB	WHATMAN	S&S	M&N	SARTORIUS
F5900	603g	603g	649	Grade 40

1.6.3 Quartz microfiber thimbles

CHM® quartz microfiber thimbles are made from high purity quartz microfiber. These thimbles are able to withstand high temperatures (up to 900°C), and meet the highest requirements for purity, specially because of their low heavy metal content.

Features

Manufactured in high-purity quartz microfiber filters (SiO₂) free of binding elements or additives

High loading capacity

High retention of very small particles

High air permeability

Good stability in high temperature. Maximum working temperature 900°C

Tolerances for F5990 micro-quartz thimbles:

- Internal diameter +0/-3mm
- Thimble height ±1mm
- Wall thickness 2 ±0.5mm

Applications

Gas emission controls for industrial chimneys

Gravimetric testing for dust in hot gases

Determination of environmental pollutants

Extraction in highly concentrated acid or alkaline solutions

Technical Specifications

Grade	Retention Dop (*) (%)	Maximum Temperature (°C)	Binder
F5990	99.998	900	NO

(*) Retention of a Dyoptil Ophtalate fog with 0.3 µm particles.

Order Information

(*) Size (mm) Int x Lenght	Order Number
25 Thimbles/Box	
19x90	F5990-19090
22x65	F5990-22065
22x90	F5990-22090
25x80	F5990-25080
25x100	F5990-25100
30x100	F5990-30100
35x150	F5990-35150
43x123	F5990-43123

(*) Other sizes available under request.

Equivalence Table

CHMLAB	WHATMAN	S&S	M&N	SARTORIUS
F5990	603q	603q	-	MK 360

1.7 Surface protection

1.7.1 Filter paper in reams

The range of CHM® filter paper reams is made from high-quality cellulose fibers, assuring good wet strength and high absorption capacity, being these, essential features of these papers.

F4573 GRADE - Thick paper

This is the thickest quality in the range. Particularly suitable for general laboratory work requiring high absorption power.

F4560 GRADE - Medium thickness

Filter paper of medium thickness and basis weight with excellent absorption properties. Available in reams and other formats.

F4550 GRADE - Thin

This paper is thinner and has a lower basis weight than the other references.

Technical Specifications

Grade	Weight (g/m ²)	Thickness (µm)	Absorption Klemm (*) (mm/10min)
F4573	73	170	75/70
F4560	60	130	60/55
F4550	50	115	55/55

(*) (Longitudinal sense/Transversal sense).

Order Information

Size (mm)	F4573	F4560	F4550
500 Sheets/Box			
320x420	F4573-320420Q	F4560-320420Q	F4550-320420Q
420x520	F4573-420520Q	F4560-420520Q	F4550-420520Q
500x500	F4573-500500Q	F4560-500500Q	F4550-500500Q
520x520	F4573-520520Q	F4560-520520Q	F4550-520520Q
580x580	F4573-580580Q	F4560-580580Q	F4550-580580Q



1.7.2 Absorbent paper with polyethylene

F1505 and **F1506 GRADE** are two-layer highly absorptive grades of coated paper.

Features

The top layer to captures any spills consists of highly absorbent cellulose. The bottom layer made out of polyethylene, prevents the covered surface from contamination

Used with the polyethylene side up, the papers are highly useful for recovery of valuable or toxic liquids

Coated surface protection papers can be treated with disinfectants for the use in clinical laboratories to prevent biological contamination

Applications

Preventing radioactive contamination of working surfaces in radiochemical laboratories

Recovering spilt solutions containing expensive reagents

Protecting laboratory bench surfaces from spillage or splashes of liquids by preventing absorption and seepage of these liquids into work surfaces

Lining animal cages for protection and hygiene

Reducing the risk of objects breaking after falling on hard surfaces because the carrier material reduces the impact

Technical Specifications

Grade	Weight (g/m ²)	Area Absorption (g water/m ²)	Features
F1505	125	240	Highly absorbent
F1506	210	410	Ultra absorbent

Order Information

Size (mm)	F1505	F1506
100 Sheets/Box (*)		
320x420	F1505-320420H	F1506-320420H
420x520	F1505-420520H	F1506-420520H
460x570	F1505-460570H	F1506-460570H
480x600	F1505-480600H	F1506-480600H
500x500	F1505-500500H	F1506-500500H
1 Reel/Pack		
500mmx50m	F1505-500050B	F1506-500050B
500mmx100m	F1505-500100B	F1506-500100B

(*) Packaging of 500 sheets is also available under request.

Equivalence Table

CHMLAB	WHATMAN	S&S	M&N	SARTORIUS
F1505	BENCHKOTE	295PE	210PE	LABSORB
F1506	BENCHKOTE Plus	296PE	-	LABSORB ULTRA

1.8 Phase separation paper

The CHM® phase separator paper is a hydrophobic paper impregnated with stabilized silicone for routine solvent extraction. It separates the aqueous phase from the organic phase, retaining the solid components and the aqueous phase in the funnel. The solvent phase flows through the paper, obtaining a clean, particle-free organic phase.

The phase separator paper can be used for all types of organic solutions, such as ether, petroleum, chloroform, etc.

Applications

Solvent extraction

Filtration of organic solvents from the aqueous phase

Separation of emulsions

Order Information

Diameter (mm)	Order Number	Quantity/Box
70	P1000-070	100
80	P1000-080	100
90	P1000-090	100
100	P1000-100	100
110	P1000-110	100
125	P1000-125	100
150	P1000-150	100
185	P1000-185	100
200	P1000-200	100
240	P1000-240	100
270	P1000-270	100
320	P1000-320	100

(*) Add an F at the end of the reference for folded circles (e.g. P1000-150F). Other sizes and packaging are available under request.

Equivalence Table

CHMLAB	WHATMAN	S&S	M&N	SARTORIUS
P1000	1PS	597hy	616WA	480

1.9 Technical filter papers for special analysis

Technical filter papers for special analysis, used in certain tests and processes due to their special features

Grade	Applications
F3001	Preparing and cleaning of wine musts
F3002	Determination of the water absorption coefficient by capillarity of hardened mortar according to EN 1015-18
F3003	Determination of the performance of olive oils in automatic analyzers
F3004	Determination of the content of impurities in raw milk and dairy products according to GB 5413.30
F3005	Determination of the resistance of lacquered furniture surfaces to cold liquids by potentiometry according to the UNE 89401 standard.
F3006	Determination of the water retention power of paste mortars according to ISO 5269-1: 1998

Technical Specifications

Grade	Types of filter	Weight (g/m ²)	Thickness (μm)
F3001	Technical filter paper	100	240
F3002	Absorbent paper	185	410
F3003	Technical filter paper	85	150
F3004	Non-woven filter	125	190
F3005	Absorbent paper	450	990
F3006	Drying paper	650	1500

Order Information

Diameter (mm)	F3001	F3002	F3003	F3004	F3005	F3006
1000 Circles/Box						
25	-	-	-	-	F3005-025	-
32	-	-	-	F3004-032	-	-
100 Circles/Box						
70	-	-	F3003-070	-	-	-
110	-	-	-	-	-	F3006-110
185	F3001-185	-	-	-	-	-
200	F3001- 200	-	-	-	-	-
240	F3001-240	-	-	-	-	-
Size (mm)	F3001	F3002	F3003	F3004	F3005	F3006
100 Sheets/Pack						
150x175	-	F3002-150175	-	-	-	-

Equivalence Table

CHMLAB	Properties	S&S	M&N
F3001	Medium filtration	3205	-
F3002	Absorbent paper	22	MN960
F3003	Slow filtration	-	-
F3004	Non-woven filter	0980/1	-
F3005	Absorbent paper	2282	MN440
F3006	Drying paper	2727	-

1.10 pH Indicator and test papers

CHMLAB offers a wide range of high-quality test papers for rapid determination of pH values.

Universal plastic strips (non-bleed)

The indicator pads on these environmentally friendly strips are prepared as a non-bleed system, therefore, the resultant colours change remains far longer and readable until the pad is dry. Each strip is long enough to protect the user from the test solution as the test pads are at the extreme end of the strip. For accurate pH readings, these strips use 4 different indicator pads and the colours on the enclosed colour chart match the colour and position of each pad on the strip. This allows these strips to provide a rapid method of measuring the pH of a solution while producing high-quality results each time.

Strips with the non-bleed system provide precise pH values as the different colours do not mix at the point of testing.

Test papers

Universal Test Indicator Paper is one of the most popular pH test papers. They provide a quick and easy method of indicating the pH of a solution by using a single color change which can be matched to the color chart. Universal pH indicator papers are available in different ranges of pH to give the user the level of accuracy needed (intervals of 0.2 - 0.3 - 0.5 - 1.0 pH).

Features

High-quality full-range test papers

Instant and portable pH reading

Available in reels and strips

Simple to use and economical

Combine easy-to-use with accuracy, reliability and consistency

Applications

Quick determination of pH values in laboratories, industries and schools

pH determinations in fieldwork (outside the laboratories)

Order Information

Scale	pH range/Scale	Presentation	Order Number
pH 0 – 14 pad (4 pad)	Universal Indicator Strips pH 0 – 14, pH 0 – 1 – 2 – 3 – 4 – 5 6 – 7 – 8 – 9 – 10 – 11 – 12 -13 – 14	100 strips per pack	E2000-0014H
pH 0 – 14	pH 0 – 1 – 2 – 3 – 4 – 5 – 6 – 7 – 8 – 9 – 10 – 11 – 12 -13 – 14	1 reel (5 m x 7 mm) 200 strips per pack	E2001-0014R E2001-0014D
pH 1 – 11	pH 1 – 2 – 3 – 4 – 5 – 6 – 7 – 8 – 9 – 10 – 11	1 reel (5 m x 7 mm)	E2001-0111R
pH 1.0 – 3.5	pH 1.0 – 1.5 -2.0 -2.5 – 3.0 – 3.5	200 strips per pack 1 reel (5 m x 7 mm)	E2001-1035D E2001-1035R
pH 3.6 – 5.1	pH 3.6 – 3.9 – 4.2 – 4.8 – 5.1	200 strips per pack 1 reel (5 m x 7 mm)	E2001-3651D E2001-3651R
pH 4.0-5.6	pH 4.0 – 4.2 – 4.4 – 4.6 – 4.8 – 5.0 – 5.2 – 5.4 – 5.6	200 strips per pack 1 reel (5 m x 7 mm)	E2001-4056D E2001-4056R
pH 4.0-8.0	pH 4.0 – 4.5 – 5.0 – 5.5 – 6.0 – 6.5 – 7.0 – 7.5 – 8.0	200 strips per pack 1 reel (5 m x 7 mm)	E2001-4080D E2001-4080R
pH 5.2-6.7	pH 5.2 – 5.5 – 5.8 – 6.1 – 6.4 – 6.7	200 strips per pack 1 reel (5 m x 7 mm)	E2001-5267D E2001-5267R
pH 6.2-7.8	pH 6.2 – 6.4 – 6.6 – 6.8 – 7.0 – 7.2 – 7.4 – 7.6 – 7.8	200 strips per pack 1 reel (5 m x 7 mm)	E2001-6278D E2001-6278R
pH 6.8-8.3	pH 6.8 – 7.1 – 7.4 – 7.7 – 8.0 – 8.3	200 strips per pack 1 reel (5m x 7mm)	E2001-6883D E2001-6883R
pH 8.4-10.0	pH 8.4 – 8.7 – 9.0 – 9.3 – 9.6 – 10.0	200 strips per pack 1 reel (5 m x 7 mm)	E2001-8410D E2001-8410R
pH 9.0-13.0	pH 9.0 – 9.5 – 10.0 – 10.5 – 11.0 – 11.5 – 12.0 – 12.5 – 13.0	200 strips per pack 1 reel (5 m x 7 mm)	E2001-9013D E2001-9013R
pH 12.0-14.0	pH 12.0 – 12.5 – 13.0 – 13.5 – 14.0	200 strips per pack 1 reel (5 m x 7 mm)	E2001-1214D E2001-1214R

(*) Other test papers available under request.

02

MICROFILTRATION

2.1	Membrane Filters	47
2.1.1	MCA Cellulose acetate membrane filters	47
2.1.2	MRC Regenerated cellulose membrane filters	49
2.1.3	Cellulose nitrate (mixed cellulose ester) membrane filters	50
2.1.3.1	MCN Cellulose nitrate (mixed cellulose ester) membrane filters	51
2.1.3.2	MNW, MNB, MNG Mixed cellulose ester gridded membrane filters for microbiological analysis	53
2.1.4	MPC Polycarbonate track-etched membranes	56
2.1.5	MNY Polyamide 66 (Nylon) membrane filters	58
2.1.6	MTF/H PTFE Hydrophobic membrane filters	60
2.1.7	MTF/L PTFE Hydrophilic membrane filters	61
2.1.8	PTFE membranes PM2.5 for particle analysis in air	62
2.1.9	MPV/H Hydrophobic polyvinylidene fluoride (PVDF) membrane filters	64
2.1.10	MPV/L Hydrophilic polyvinylidene fluoride (PVDF) membrane filters	65
2.1.11	MPP Polypropylene membrane filters	66
2.1.12	MPE Polyethersulfone membrane filters	67
2.2	Syringe filters	68
2.2.1	SCA Cellulose acetate syringe filters	68
2.2.2	SNY Polyamide 66 (Nylon) syringe filters	70
2.2.3	SRC Regenerated cellulose syringe filters	72
2.2.4	STF/H PTFE Hydrophobic syringe filters	74
2.2.5	STF/L PTFE Hydrophilic syringe filters	76
2.2.6	SPP Polypropylene syringe filters	78

2.2.7	SPV/L Hydrophilic polyvinylidene fluoride (PVDF) syringe filters	80
2.2.8	SPV/H Hydrophobic polyvinylidene fluoride (PVDF) syringe filters	82
2.2.9	SPE Polyethersulfone (PES) syringe filters	84
2.2.10	SCE Mixed cellulose esters syringe filters	85
2.2.11	SGF Glass microfiber pre-filter syringe filters	86
2.2.12	S+GF Glass microfiber prefilter + syringe filter + membrane SF	87
2.3	Venting filters	88
2.4	BIO-tr@ns blotting membranes	90
2.4.1	BIO-tr@ns pure and supported nitrocellulose membrane	91
2.4.2	BIO-tr@ns PVDF membrane	92
2.4.3	BIO-tr@ns neutral and reprobing charged Nylon membrane	93
2.5	Microbiological monitors	94
2.6	Membrane hardware	96
2.6.1	1-, 3- and 6-branch CHM®FR stainless steel manifold	96
2.6.2	Filter holders	98
2.6.2.1	Glass filtration system	98
2.6.2.2	Polycarbonate filtration system	99
2.6.2.3	Stainless steel vacuum filtration support	100
2.6.2.4	Stainless steel filter holder	101
2.6.2.5	Polycarbonate filter holder	102
2.6.2.6	PTFE filter holder	103
2.6.3	Membrane dispenser	104
2.7	Sterile disposable vacuum filtration units	106

02

MICROFILTRATION

Microfiltration is a membrane technical filtration process which removes contaminants from a fluid (liquid or gas) by passing through a microporous membrane.

Membrane filters are surface filters with a precise micro-porous structure. They are used to separate, remove particles or collect micro-organisms for analysis from a fluid.

Particles bigger than the absolute porosity remain on the filter surface, whilst smaller particles go through the filter unless other interactions into the filter retain them in the filter matrix.

The microfiltration cover slower range of particle retention than the filtration with the filter papers (depth filters).

Membranes are made of different polymers and are available in several diameters and pore sizes.

Membrane filters are used in microbiological quality control procedures for a wide range of industries; food, beverage, pharmaceutical, cosmetics, etc.

2.1 Membrane filters



2.1.1 MCA Cellulose acetate membrane filters

Cellulose Acetate membranes type MCA are composed of pure cellulose acetate.

Its uniform pore size and consistent flow rates ensure reliable performance.

These membranes combine high flow rates and thermal stability with very low adsorption characteristics.

Features

Hydrophilic membrane

Compatible to aqueous solutions with pH 4-8, most alcohols, hydrocarbons and oils

Low extractables

Very low protein adsorption

Autoclavable

Exceptional dimensional strength and low binding characteristics

High flow rate

Maximum working temperature: 180 °C

Applications

Aqueous solutions filtration

Protein and enzyme filtration

Biological and clinical analysis

Tissue culture media sterilization

Technical Specifications

Pore Size	0.2 µm	0.45 µm	0.65 µm	0.8 µm
Bubble point ⁽¹⁾	2.9 bar	1.9 bar	1.5 bar	1.0 bar
Flow rates ⁽²⁾	24 ml/min/cm ² /bar	69 ml/min/cm ² /bar	115 ml/min/cm ² /bar	200 ml/min/cm ² /bar
Filter diameter	13 mm, 25 mm, 47 mm, 50 mm, 90 mm, 142 mm, 293 mm (other sizes available under request)			
Material	Cellulose Acetate			
Thickness average	135 µm			
Sterilization	By autoclaving at 121 °C or 134°C, with gamma-radiation or with ethylene oxide			
Thermal stability	Max. 180 °C			
Chemical compatibility	Resistant to aqueous solutions in pH range 4-8, to most alcohols, hydrocarbons and oils (see chemical compatibility table)			
Extractables	< 1%			

⁽¹⁾ Minimum value, wetted with water.

⁽²⁾ Typical values per cm² for water.

Order Information

Order Number	Pore Size (*) (μm)	Diameter (**) (mm)	Sterile	Quantity/Box
MCA020013H	0.2	13	NO	100
MCA020025H	0.2	25	NO	100
MCA020047H	0.2	47	NO	100
MCA020050H	0.2	50	NO	100
MCA020090T	0.2	90	NO	25
MCA020142T	0.2	142	NO	25
MCA020293T	0.2	293	NO	25
MCA045013H	0.45	13	NO	100
MCA045025H	0.45	25	NO	100
MCA045047H	0.45	47	NO	100
MCA045050H	0.45	50	NO	100
MCA045090T	0.45	90	NO	25
MCA045142T	0.45	142	NO	25
MCA045293T	0.45	293	NO	25
MCA065013H	0.65	13	NO	100
MCA065025H	0.65	25	NO	100
MCA065047H	0.65	47	NO	100
MCA065050H	0.65	50	NO	100
MCA065090T	0.65	90	NO	25
MCA065142T	0.65	142	NO	25
MCA065293T	0.65	293	NO	25
MCA080013H	0.8	13	NO	100
MCA080025H	0.8	25	NO	100
MCA080047H	0.8	47	NO	100
MCA080050H	0.8	50	NO	100
MCA080090T	0.8	90	NO	25
MCA080142T	0.8	142	NO	25
MCA080293T	0.8	293	NO	25

(*) Also available in other pore sizes up to 5 μm . (**) Other diameters available under request.

2.1.2 MRC Regenerated cellulose membrane filters

Regenerated Cellulose membranes type MRC are made of regenerated cellulose.

These solvent-resistant hydrophilic membrane filters are perfectly suited for particle removal from solvents.

Often used for ultra-cleaning and de-gassing solvents and mobile phases for HPLC in combination with the All-glass holder (our references FS047300T and FS047300S).

Features

Hydrophilic membrane
Excellent chemical compatibility and resistance to organic solvents (pH 3-12)
Low non-specific adsorption
Superior thermal resistance
High mechanical strength

Applications

Filtration of aqueous and organic solutions
Particle removal from organic solvents or mixtures of aqueous and non-aqueous samples
Ultra-cleaning and de-gassing solvents and mobile phases for HPLC
Clarification
Protein chemistry

Technical Specifications

Pore Size	0.2 μm	0.45 μm
Bubble point ⁽¹⁾	4.4 bar	2.9 bar
Flow rates ⁽²⁾	15 ml/min/cm ² /bar	30 ml/min/cm ² /bar
Filter diameter	13 mm, 25 mm, 47 mm, 50 mm, 90 mm, 142 mm, 293 mm. (Other diameter sizes available under request)	
Material	Regenerated cellulose reinforced with nonwoven cellulose	
Thickness average	160-200 μm	
Sterilization	By autoclaving at 121 °C or 134°C with gamma-radiation or with ethylene oxide	
Chemical compatibility	Resistant to almost all solvents and to aqueous solutions in the pH range 3-12 (see chemical compatibility table)	
Extractables	< 1%	

⁽¹⁾ Minimum value, wetted with water.

⁽²⁾ Typical values per cm² for water.

Order Information

Order Number	Pore Size (μm)	Diameter (*) (mm)	Sterile	Quantity/Box
MRC020013H	0.2	13	NO	100
MRC020025H	0.2	25	NO	100
MRC020047H	0.2	47	NO	100
MRC020050H	0.2	50	NO	100
MRC020090T	0.2	90	NO	25
MRC020142T	0.2	142	NO	25
MRC020293T	0.2	293	NO	25
MRC045013H	0.45	13	NO	100
MRC045025H	0.45	25	NO	100
MRC045047H	0.45	47	NO	100
MRC045050H	0.45	50	NO	100
MRC045090T	0.45	90	NO	25
MRC045142T	0.45	142	NO	25
MRC045293T	0.45	293	NO	25

(*) Other diameters available under request

2.1.3 Cellulose nitrate (mixed cellulose ester) membrane filters

Cellulose Nitrate also called Mixed Cellulose Ester membrane filters are composed of cellulose nitrate and a small content of cellulose acetate.

They are available in white, black or green, gridded (3.1 x 3.1 mm) or plain and sterile or non-sterile.

They are ready-to-use membranes which save preparatory time.

Features

Hydrophilic membrane

Made of mixed cellulose esters.

This material guarantees excellent retention and optimum colony growth

Very uniform pore structure which ensures a homogeneous distribution of the particles retained on the filter surface

Various colours give the best contrast to the colonies which are to be counted

Maximum working temperature: 130°C

Autoclavable

Very high flow rate

Applications

Clarification and sterilisation of aqueous solutions

Microbiological analysis and particle counts

Particle size analysis

Pre-filtration and clarification of samples prior to further analysis

Removal of particles in suspensions to determine the degree of impurity



2.1.3.1 White MCN Cellulose nitrate (mixed cellulose ester) membrane filters

Technical Specifications

Pore Size	0.2 µm	0.45 µm	0.65 µm	0.8 µm	1.2 µm	3 µm	5 µm	8 µm
Bubble point ⁽¹⁾	4.2 bar	2.4 bar	2.0 bar	1.4 bar	1.0 bar	0.6 bar	0.5 bar	0.3 bar
Flow rates ⁽²⁾	25 ml/min/ cm ² /bar	69 ml/min/ cm ² /bar	130 ml/ min/cm ² /bar	200 ml/ min/cm ² /bar	320 ml/ min/cm ² /bar	430 ml/ min/cm ² /bar	570 ml/ min/cm ² /bar	750 ml/ min/cm ² /bar
Filter diameter	13 mm, 25 mm, 47 mm, 50 mm, 90 mm, 142 mm, 293 mm. (Other diameter sizes available under request)							
Material	Mixed cellulose esters							
Thickness average	Between 115 µm and 140 µm according to different pore sizes							
Sterilization	By autoclaving (at 121 °C), with gamma radiation or with ethylene oxide							
Thermal stability	Max. 130 °C							
Chemical compatibility	Resistant to aqueous solutions in the pH range 4-8, to hydrocarbons and to some solvents (see chemical compatibility table)							
Extractables	With water less than 1%							

⁽¹⁾ Minimum value, wetted with water.

⁽²⁾ Typical values per cm² for water.

Order Information

Order Number	Pore Size (µm)	Diameter (*) (mm)	Sterile	Quantity/Box
CHM® MCN – Mixed cellulose esters White Membranes. Smooth surface				
MCN020013H	0.2	13	NO	100
MCN020025H	0.2	25	NO	100
MCN020047H	0.2	47	NO	100
MCN020047H-S	0.2	47	YES	100
MCN020050H	0.2	50	NO	100
MCN020090T	0.2	90	NO	25
MCN020142T	0.2	142	NO	25
MCN020293T	0.2	293	NO	25
MCN045013H	0.45	13	NO	100
MCN045025H	0.45	25	NO	100
MCN045047H	0.45	47	NO	100
MCN045047H-S	0.45	47	YES	100
MCN045050H	0.45	50	NO	100
MCN045090T	0.45	90	NO	25
MCN045142T	0.45	142	NO	25
MCN045293T	0.45	293	NO	25
MCN065013H	0.65	13	NO	100
MCN065025H	0.65	25	NO	100
MCN065047H	0.65	47	NO	100
MCN065047H-S	0.65	47	YES	100
MCN065050H	0.65	50	NO	100
MCN065090T	0.65	90	NO	25

Order Information

Order Number	Pore Size (μm)	Diameter (*) (mm)	Sterile	Quantity/Box
MCN065142T	0.65	142	NO	25
MCN065293T	0.65	293	NO	25
MCN080025H	0.8	25	NO	100
MCN080047H	0.8	47	NO	100
MCN080047H-S	0.8	47	YES	100
MCN080050H	0.8	50	NO	100
MCN080090T	0.8	90	NO	25
MCN080142T	0.8	142	NO	25
MCN080293T	0.8	293	NO	25
MCN120013H	1.2	13	NO	100
MCN120025H	1.2	25	NO	100
MCN120047H	1.2	47	NO	100
MCN120047H-S	1.2	47	YES	100
MCN120050H	1.2	50	NO	100
MCN120090T	1.2	90	NO	25
MCN120142T	1.2	142	NO	25
MCN120293T	1.2	293	NO	25
MCN300013H	3	13	NO	100
MCN300025H	3	25	NO	100
MCN300047H	3	47	NO	100
MCN300047H-S	3	47	YES	100
MCN300050H	3	50	NO	100
MCN300090T	3	90	NO	25
MCN300142T	3	142	NO	25
MCN300293T	3	293	NO	25
MCN500013H	5	13	NO	100
MCN500025H	5	25	NO	100
MCN500047H	5	47	NO	100
MCN500050H	5	50	NO	100
MCN500090T	5	90	NO	25
MCN500142T	5	142	NO	25
MCN500293T	5	293	NO	25
MCN800013H	8	13	NO	100
MCN800025H	8	25	NO	100
MCN800047H	8	47	NO	100
MCN800047H-S	8	47	YES	100
MCN800050H	8	50	NO	100
MCN800090T	8	90	NO	25
MCN800142T	8	142	NO	25
MCN800293T	8	293	NO	25

(*) Other diameters available under request

2.1.3.2 MNW, MNB, MNG Mixed cellulose ester gridded membrane filters for microbiological analysis

Mixed cellulose esters gridded membranes, sterile and individually packed, for colony counts in routine microbiological quality control.

They are ready-to-use membranes and save preparatory time.

The grid size is 3.1 x 3.1 mm.

Available in various colours in order to ensure the best contrast to the colonies to be counted (white, black and green).

Also available with hydrophobic edges.

Hydrophobic edge membranes are used mainly in the sterility testing solutions containing antibiotics.



Order Information

Order Number	Pore Size (μm)	Diameter (mm)	Sterile	Quantity/Box
CHM® MNW – Mixed cellulose esters White Membranes. Black grid				
MNW020047H-SG	0.2	47	YES	100
MNW020047M-SG	0.2	47	YES	1000
MNW020047H-G	0.2	47	NO	100
MNW020047R-SG (*)	0.2	47	YES	300
MNW045025H-SG	0.45	25	YES	100
MNW045047H-SG	0.45	47	YES	100
MNW045047M-SG	0.45	47	YES	1000
MNW045047H-G	0.45	47	NO	100
MNW045047R-SG (*)	0.45	47	YES	300
MNW065047H-SG	0.65	47	YES	100
MNW065047M-SG	0.65	47	YES	1000
MNW065047H-G	0.65	47	NO	100
MNW080047H-SG	0.8	47	YES	100
MNW080047M-SG	0.8	47	YES	1000
MNW080047H-G	0.8	47	NO	100
MNW080047R-SG (*)	0.8	47	YES	300
MNW120047H-SG	1.2	47	YES	100
MNW120047M-SG	1.2	47	YES	1000
MNW120047H-G	1.2	47	NO	100
MNW300047H-SG	3.0	47	YES	100
MNW300047M-SG	3.0	47	YES	1000
MNW800047H-SG	8.0	47	YES	100
MNW800047M-SG	8.0	47	YES	1000

Order Number	Pore Size (μm)	Diameter (mm)	Sterile	Quantity/Box
CHM® MNB – Mixed cellulose esters Black Membranes. White Grid. For the detection of yeasts and moulds				
MNB020047H-SW	0.2	47	YES	100
MNB020047M-SW	0.2	47	YES	1000
MNB045047H-SW	0.45	47	YES	100
MNB045047M-SW	0.45	47	YES	1000
MNB045047R-SW (*)	0.45	47	YES	300
MNB065047H-SW	0.65	47	YES	100
MNB065047M-SW	0.65	47	YES	1000
MNB065047R-SW (*)	0.65	47	YES	300
MNB080047H-SW	0.8	47	YES	100
MNB080047M-SW	0.8	47	YES	1000
MNB080047R-SW (*)	0.8	47	YES	300
Order Number	Pore Size (μm)	Diameter (mm)	Sterile	Quantity/Box
CHM® MNG - Mixed cellulose esters Green Membranes. Dark Green Grid. For colony counts				
MNG045047H-SV	0.45	47	YES	100
MNG045047M-SV	0.45	47	YES	1000
Order Number	Pore Size (μm)	Diameter (mm)	Sterile	Quantity/Box
CHM® MNW - Mixed cellulose esters White Membranes. Green Grid. For E.coli and coliforms				
MNW045047H-SV	0.45	47	YES	100
MNW045047M-SV	0.45	47	YES	1000
Order Number	Pore Size (μm)	Diameter (mm)	Sterile	Quantity/Box
CHM® MNW - Mixed cellulose esters White Membranes. Black Grid. Pink hydrophobic edge				
MNW020047H-SGP3 3 mm edge	0.2	47	YES	100
MNW020050H-SGP3 3 mm edge	0.2	50	YES	100
MNW045047H-SGP3 3 mm edge	0.45	47	YES	100
MNW045050H-SGP3 3 mm edge	0.45	50	YES	100
MNW045047H-SGP6 6 mm edge	0.45	47	YES	100

(*) Pack for membrane dispenser. Compatible with MILLIPORE and SARTORIUS dispensers.
Additional information for membrane dispenser MD001 CHM® on page 100.

2.1.4 MPC Polycarbonate track-etched membrane filters

MPC Polycarbonate track-etched membranes are manufactured from high grade polycarbonate film using track-etch technology. The resulting membrane is a thin, translucent and microporous polycarbonate film with a smooth flat surface.

Their capillary pore structure is uniform and precise with a narrow pore size distribution. The surface makes them ideal for particle identification by microscopy or binocular lenses.

Provides flow control for liquids moving through the membrane capturing 100 % of cells larger than the pore size.

Available as standard in 13 different pore sizes and different diameters.

Features

Made of high grade polycarbonate film

Hydrophilic membrane

High translucency

A very smooth and shiny surface on both sides facilitates easy sample examination

Low extractables

Low protein binding

Precise pore size

Maximum working temperature: 140 °C

Applications

Particulate analysis

Epifluorescence microscopy

Fluid clarification

Cytology

Biological tests, cell biology and cell cultures

Removal of red blood cells from plasma

Water microbiology (analysis for Legionella in drinking water according to ISO 11731 part 1)

Environmental analysis (detection of AOX in water)

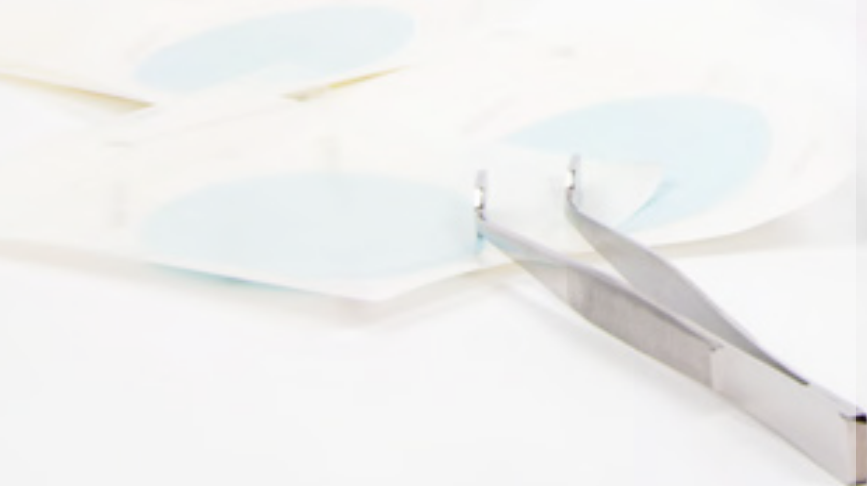

Technical Specifications

Pore Size	0.1 µm	0.2 µm	0.4 µm	0.6 µm	0.8 µm	1.0 µm
Bubble point ⁽¹⁾	2.0 bar	1.4 bar	0.8 bar	0.6 bar	0.5 bar	0.4 bar
Flow rates ⁽²⁾	2.5 ml/min/ cm ² /bar	10 ml/min/ cm ² /bar	30 ml/min/ cm ² /bar	60 ml/min/ cm ² /bar	90 ml/min/ cm ² /bar	130 ml/min/ cm ² /bar
Filter diameter	13 mm, 25 mm, 47 mm (other diameter sizes available under request)					
Material	Polycarbonate					
Thickness average	5 - 12 µm according to different pore size					
Sterilization	γ-radiation or ethylene oxide					
Thermal stability	140°C					
Chemical compatibility	See chemical compatibility table					
Extractables	Very low extractables					

⁽¹⁾ Minimum value, wetted with water. ⁽²⁾ Typical values per cm² for water.

Order Information

Order Number	Pore Size (*) (µm)	Diameter (**) (mm)	Sterile	Quantity/Box
MPC010025H	0.1	25	NO	100
MPC010047H	0.1	47	NO	100
MPC020013H	0.2	13	NO	100
MPC020025H	0.2	25	NO	100
MPC020047H	0.2	47	NO	100
MPC020047H-S	0.2	47	YES	100
MPC040013H	0.4	13	NO	100
MPC040025H	0.4	25	NO	100
MPC040047H	0.4	47	NO	100
MPC040047H-S	0.4	47	YES	100
MPC060025H	0.6	25	NO	100
MPC060047H	0.6	47	NO	100
MPC080025H	0.8	25	NO	100
MPC080047H	0.8	47	NO	100
MPC100025H	1.0	25	NO	100
MPC100047H	1.0	47	NO	100
MPC300025H	3.0	25	NO	100
MPC300047H	3.0	47	NO	100
MPC500025H	5.0	25	NO	100
MPC500047H	5.0	47	NO	100
MPC800025H	8.0	25	NO	100
MPC800047H	8.0	47	NO	100
MPC10M025H	10.0	25	NO	100
MPC10M047H	10.0	47	NO	100
MPC12M025H	12.0	25	NO	100
MPC12M047H	12.0	47	NO	100
MPC14M025H	14.0	25	NO	100
MPC14M047H	14.0	47	NO	100
MPC20M025H	20.0	25	NO	100
MPC20M047H	20.0	47	NO	100

(*) Also available in other pore sizes between 0.01 and 20 µm under request. (**) Other diameters available under request.

2.1.5 MNY Polyamide 66 (Nylon) membrane filters

High-quality Polyamide 66 membranes are suitable for filtering aqueous solutions and most organic solvents. The membranes are suitable for use with a wide range of biological preparations.

Nylon membranes are hydrophilic, removing the need for wetting agents that could be extracted when filtering aqueous solutions. The membranes are flexible, durable and tear-resistant, and can be autoclaved.

CHM® MNY Nylon membrane filters are chemically resistant to most bases, making them particularly indicated for clarification and sterilization of alkaline solutions.

These type of membranes is compatible with most aqueous samples and some organic solvents, being a good alternative for sterilization and clarification of the mobile phases for HPLC.

These membranes have high non-specific adsorption, which makes them very useful in blotting techniques, mainly for transfers and immobilizations of nucleic acids.

They are not recommended for sterilizing cellular solutions, for which application it is advisable to use the CHM® MCA cellulose acetate membranes.

Features

Made entirely of polyamide

Hydrophilic membrane

High non-specific adsorption

High mechanical stability

Low extractables

Sterilization by autoclaving (at 121°C or 134°C) or ethylene oxide

Maximum working temperature: 140°C

Applications

Sterilization and clarification of aqueous and organic solvent solutions

HPLC simple preparation

Technical Specifications

Pore Size	0.1 µm	0.2 µm	0.45 µm	0.65 µm	0.8 µm	10 µm
Bubble point ⁽¹⁾	3.2 bar (0.2 µm)		2.3 bar (0.45 µm)			
Flow rates ⁽²⁾	14 ml/min/cm ² /bar (0.2 µm)			35 ml/min/cm ² /bar (0.45 µm)		
Filter diameter	13 mm, 25 mm, 47 mm, 90 mm, 142 mm, 293 mm (Other diameter sizes available under request)					
Material	Polyamide 66 (Nylon)					
Thickness average	90-140 µm according to different pore sizes					
Sterilization	By autoclaving at 121 or 134 °C and with ethylene oxide					
Thermal stability	Max. 140 °C					
Chemical compatibility	See chemical compatibility table					
Extractables	Low extractables					

⁽¹⁾ Minimum value, wetted with water.

⁽²⁾ Typical values per cm² for water.



Order Information

Order Number	Pore Size (*) (μm)	Diameter (mm)	Sterile	Quantity/Box
MNY010013H	0.1	13	NO	100
MNY010025H	0.1	25	NO	100
MNY010047H	0.1	47	NO	100
MNY010050H	0.1	50	NO	100
MNY010090T	0.1	90	NO	25
MNY010142T	0.1	142	NO	25
MNY010293T	0.1	293	NO	25
MNY020013H	0.2	13	NO	100
MNY020025H	0.2	25	NO	100
MNY020047H	0.2	47	NO	100
MNY020050H	0.2	50	NO	100
MNY020090T	0.2	90	NO	25
MNY020142T	0.2	142	NO	25
MNY020293T	0.2	293	NO	25
MNY045013H	0.45	13	NO	100
MNY045025H	0.45	25	NO	100
MNY045047H	0.45	47	NO	100
MNY045050H	0.45	50	NO	100
MNY045090T	0.45	90	NO	25
MNY045142T	0.45	142	NO	25
MNY045293T	0.45	293	NO	25
MNY065013H	0.65	13	NO	100
MNY065025H	0.65	25	NO	100
MNY065047H	0.65	47	NO	100
MNY065050H	0.65	50	NO	100
MNY065090T	0.65	90	NO	25
MNY065142T	0.65	142	NO	25
MNY065293T	0.65	293	NO	25
MNY080013H	0.8	13	NO	100
MNY080025H	0.8	25	NO	100
MNY080047H	0.8	47	NO	100
MNY080050H	0.8	50	NO	100
MNY080090T	0.8	90	NO	25
MNY080142T	0.8	142	NO	25
MNY080293T	0.8	293	NO	25
MNY500047H	5	47	NO	100
MNY500050H	5	50	NO	100
MNY500090T	5	90	NO	25
MNY10M047H	10	47	NO	100
MNY10M050H	10	50	NO	100
MNY10M090T	10	90	NO	25

(*) Also available in other pore sizes between 0.1 and 10 μm under request.

2.1.6 MTF/H PTFE Hydrophobic membrane filters

They are made purely of hydrophobic PTFE (polytetrafluoroethylene) and are therefore permanently hydrophobic.

Unlike other (hydrophilic) filter types, they are not wetted by air humidity, allowing unhindered passage of air at low differential pressures.

CHM® MTF/H membrane filters have an excellent chemical compatibility; they are also used for the filtration of aggressive chemicals, and acids, to which other filter types are not resistant.

Due to their hydrophobic characteristics, they must be pre-wetted with ethanol or methanol before the filtration of aqueous media.

The main application of this membrane filter type is air/gas filtration.

Features

- Naturally hydrophobic
- Compatible with strong acids and aggressive solutions
- Allowing passage of air even at low differential pressure
- Sterilisation by autoclaving at 121°C or 134°C
- Extractables with water not detected

Applications

- Filtration of strong acids and aggressive solutions
- Clarifying corrosive substances, strong acids and alkalis (0.45 µm)
- Clarification of samples and mobile phases of HPLC and GC (0.45 µm)
- Sterilisation of air and gases (0.2 µm)
- Venting applications
- Phase separations

Technical Specifications

Pore Size	0.05 µm	0.1 µm	0.2 µm	0.45 µm	1.0 µm	3.0 µm	5.0 µm	10.0 µm
Bubble point ⁽¹⁾	1 bar (0.2 µm)		0.6 bar (0.45 µm)		0.45 bar (1 µm)		0.1 bar (5 µm)	
Flow rates ⁽²⁾	6 ml/min/cm ² /bar (0.2 µm)		30 ml/min/cm ² /bar (0.45 µm)		80 ml/min/cm ² /bar (1 µm)		250 ml/min/cm ² /bar (5 µm)	
Filter diameter	13 mm, 25 mm, 47 mm, 50 mm, 90 mm, 142 mm, 293 mm. (Other diameter sizes available under request)							
Material	Hydrophobic Polytetrafluoroethylene							
Thickness average	Between 150 µm and 250 µm according to different pore sizes							
Sterilization	By autoclaving at 121°C or EO							
Chemical compatibility	Resistant to almost all chemicals (see chemical compatibility table)							
Extractables	With water none detectable							

⁽¹⁾ Minimum value. ⁽²⁾ Typical values per cm² for isopropanol.

Order Information

Order Number	Pore Size (*) (µm)	Diameter (mm)	Sterile	Quantity/Box
MTF020013H/H	0.2	13	NO	100
MTF020025H/H	0.2	25	NO	100
MTF020047H/H	0.2	47	NO	100
MTF020050H/H	0.2	50	NO	100
MTF020090T/H	0.2	90	NO	25
MTF020142T/H	0.2	142	NO	25
MTF045013H/H	0.45	13	NO	100
MTF045025H/H	0.45	25	NO	100
MTF045047H/H	0.45	47	NO	100
MTF045050H/H	0.45	50	NO	100
MTF045090T/H	0.45	90	NO	25
MTF045142T/H	0.45	142	NO	25
MTF100025H/H	1	25	NO	100
MTF100047H/H	1	47	NO	100
MTF100142T/H	1	142	NO	25
MTF500025H/H	5	25	NO	100
MTF500047H/H	5	47	NO	100
MTF500142T/H	5	142	NO	25

(*) Also available in other pore sizes between 0.05 and 10 µm under request.

2.1.7 MTF/L PTFE Hydrophilic membrane filters

CHM® MTF/L Hydrophilic PTFE membrane filter enables the filtration of aqueous solutions without previous wetting.

This media is a versatile filter for aqueous and aggressive organic solvent-based solutions, and especially ideal to be used with all standard HPLC solvents.

Features

Hydrophilic membrane

Clear surface

High chemical resistance

High flow rate

Low protein adsorption

Applications

High viscosity liquids

HPLC sample preparation

High purity chemicals filtration

Fine particles removal in UP water process

Clarification process in Pharma industry

Technical Specifications

Pore Size	0.2 µm	0.45 µm
Bubble point ⁽¹⁾	1 bar	0.6 bar
Flow rates ⁽²⁾	6 ml/min/cm ² /bar	30 ml/min/cm ² /bar
Filter diameter	13 mm, 25 mm, 47 mm, 50 mm, 90 mm, 142 mm (Other diameter sizes under request)	
Material	Hydrophilic Polytetrafluoroethylene	
Thickness average	Between 190 µm and 220 µm according to different pore sizes	
Sterilization	By autoclaving at 121 or EO	
Chemical compatibility	See chemical compatibility table	

⁽¹⁾ Minimum value, wetted with water. ⁽²⁾ Typical values per cm² for water.

Order Information

Order Number	Pore Size (*) (µm)	Diameter (mm)	Sterile	Quantity/Box
MTF020013H/L	0.2	13	NO	100
MTF020025H/L	0.2	25	NO	100
MTF020047H/L	0.2	47	NO	100
MTF020050H/L	0.2	50	NO	100
MTF020090T/L	0.2	90	NO	25
MTF020142T/L	0.2	142	NO	25
MTF045013H/L	0.45	13	NO	100
MTF045025H/L	0.45	25	NO	100
MTF045047H/L	0.45	47	NO	100
MTF045050H/L	0.45	50	NO	100
MTF045090T/L	0.45	90	NO	25
MTF045142T/L	0.45	142	NO	25

(*) Also available in other pore sizes between 0.1 and 0.65 µm under request.

2.1.8 PTFE membranes PM2.5 for particle analysis in air

The CHM® PM 2.5 membranes are made from PTFE material and each membrane is sequentially numbered with chemically resistant polypropylene support ring,

These PM 2.5 PTFE membranes are chemically resistant with low chemical background interference (e.g. combustion particles, organic compounds and metals) allowing to carry out sensitive determinations.

Accurate gravimetric determination can be allowed thanks to their low tare mass.

Air quality, along with water quality, is one of the most important parameters that we need to constantly assess.

One of the most accurate and critical points of air analysis is the analysis of suspended particles below 2.5 μm for the possible harmful effects they may have on the human body. Thanks to their size these particles can penetrate the deeper parts of the lungs being potentially extremely dangerous.

Unit-specific numbering helps record the results of subsequent analysis using ICP-MS (coupled plasma mass spectrometry) or XRF (X-ray Fluorescence).

Applications

The following industries should be monitoring particulate matter:

Mines and quarries

Cement factories

Construction/demolition sites

Petrochemicals

Agricultural/Waste

Features

Specifications according to standard EPA40 CFR part 50, appendix L

Numeric code specified in each membrane

No particle detachment

Excellent chemical stability

High sensitivity and extremely low in extractables

Designed for use in robotic air analysers



Technical Specifications

Membrane material	Hydrophobic PTFE
Pore size	2.0 µm according to test method ASTM D2986-95a
Diameter	46.2 ± 0.25 mm
Thickness	50 ± 10 µm
Support ring media	Polypropylene (PP)
Support ring thickness	0.38 ± 0.04 mm
Support ring width	3.68 ± 0.51 mm
Particle retention (0.3 µm)	> 99.7%
Pressure drop (0.3 µm) at 16.67 l/min clean air	30 cm water column
Alkalinity	<25 µeq/g of filter Test method: Section 2.12 EPA/600/R-94/038b < 62.63 mg/l CaCO ₃

Order Information

Order Number	Pore Size (µm)	Diameter (mm)	Support Ring	Quantity/Box
MTF200046K-PM	2.0	46.2	YES	50



2.1.9 MPV/L PVDF Hydrophilic membrane filters

CHM® MPV/L membrane filters are made of Hydrophilic Polyvinylidene Fluoride and provide high flow rates and throughput, low extractables and broad chemical compatibility. These membrane filters are non-sterile and are supplied in pore sizes 0.2 and 0.45 µm, and different diameters.

Features

Hydrophilic membrane
Low extractables
Excellent chemical compatibility with aggressive solvents, acids and alcohols
Sterilisation: by γ -radiation or Ethylene Oxide
Maximum operating temperature: 135°C

Applications

Filtration of aqueous and organic solutions
Analytical sample preparation
Chromatography
Clarification
Protein chemistry

Technical Specifications

Pore Size	0.2 µm	0.45 µm
Bubble point ⁽¹⁾	1.9 bar	1.5 bar
Flow rates ⁽²⁾	10 ml/min/cm ² /bar	70 ml/min/cm ² /bar
Filter diameter	13 mm, 25 mm, 47 mm, 50 mm, 90 mm, 142 mm (Other diameter sizes available under request)	
Material	Hydrophilic Polyvinylidene Fluoride	
Thickness average	Between 150 µm and 200 µm according to different pore sizes	
Thermal stability	Max. 135 °C	
Chemical compatibility	See chemical compatibility table	

⁽¹⁾ Minimum value, wetted with water. ⁽²⁾ Typical values per cm² for water.

Order Information

Order Number	Pore Size (µm)	Diameter (mm)	Sterile	Quantity/Box
MPV020013H/L	0.2	13	NO	100
MPV020025H/L	0.2	25	NO	100
MPV020047H/L	0.2	47	NO	100
MPV020050H/L	0.2	50	NO	100
MPV020090T/L	0.2	90	NO	25
MPV020142T/L	0.2	142	NO	25
MPV045013H/L	0.45	13	NO	100
MPV045025H/L	0.45	25	NO	100
MPV045047H/L	0.45	47	NO	100
MPV045050H/L	0.45	50	NO	100
MPV045090T/L	0.45	90	NO	25
MPV045142T/L	0.45	142	NO	25

2.1.10 MPV/H PVDF Hydrophobic membrane filters

CHM® MPV/H membrane filters are made of Hydrophobic Polyvinylidene Fluoride. It is treated with a validated process which has the hydrophobic features.

These membrane filters are non-sterile and are supplied in pore sizes 0.2 and 0.45 µm, and different diameters.

Features

Hydrophobic membrane

High flow rate

Low Extractables

Broad chemical compatibility

Maximum operating temperature: 85°C

Applications

Solvent filtration

Air/Gas purification

Venting

Sample preparation

Technical Specifications

Pore Size	0.2 µm	0.45 µm
Bubble point ⁽¹⁾	1.0 bar	0.4 bar
Flow rates ⁽²⁾	3 ml/min/cm ² /bar	7 ml/min/cm ² /bar
Filter diameter	13 mm, 25 mm, 47 mm, 50 mm, 90 mm, 142 mm (Other diameter sizes available under request)	
Material	Hydrophobic Polyvinylidene Fluoride	
Thickness average	Between 90 and 100 µm according to different pore sizes	
Thermal stability	Max. 135 °C	
Chemical compatibility	See chemical compatibility table	

⁽¹⁾ Minimum value, wetted with alcohol. ⁽²⁾ Typical values per cm² for alcohol.

Order Information

Order Number	Pore Size (*) (µm)	Diameter (mm)	Sterile	Quantity/Box
MPV020013H/H	0.2	13	NO	100
MPV020025H/H	0.2	25	NO	100
MPV020047H/H	0.2	47	NO	100
MPV020050H/H	0.2	50	NO	100
MPV020090T/H	0.2	90	NO	25
MPV020142T/H	0.2	142	NO	25
MPV045013H/H	0.45	13	NO	100
MPV045025H/H	0.45	25	NO	100
MPV045047H/H	0.45	47	NO	100
MPV045050H/H	0.45	50	NO	100
MPV045090T/H	0.45	90	NO	25
MPV045142T/H	0.45	142	NO	25

(*) Also available in other pore sizes between 0.1 and 5 µm under request.

2.1.11 MPP Polypropylene membrane filters

CHM® MPP Polypropylene membrane filters are composed of pure polypropylene with absolute pore size ratings. Because of their hydrophobic nature, the polypropylene membranes are best suited for industrial processes such as gas filtration, chemical processes and photo-resist production as well as for application in the automotive industry.

Due to polypropylene is a pure hydrocarbon material, there are no disposal problems relating to halogen content with PP membrane in contrast with other hydrophobic membranes such as PVDF or PTFE.

They are supplied as standard in 0.2 and 0.45 µm pore sizes, and in different diameters.

Features

Hydrophobic membrane

Broad chemical compatibility

High thermostability

Binds proteins, DNA and RNA

Maximum operating temperature: 82°C

Applications

Aqueous and organic solvent filtration

HPLC sample preparation

Gas filtration

Technical Specifications

Pore Size	0.2 µm	0.45 µm
Bubble point ⁽¹⁾	1.0 bar	0.75 bar
Flow rates ⁽²⁾	13 ml/min/cm ² /bar	22 ml/min/cm ² /bar
Filter diameter	13 mm, 25 mm, 47 mm, 50 mm, 90 mm, 142 mm. (Other diameter sizes available under request)	
Material	Polypropylene	
Thickness average	Between 110 µm and 120 µm according to different pore size	
Thermal stability	Max. 85 °C	
Sterilization	Ethylene oxide	
Chemical compatibility	See chemical compatibility table	

⁽¹⁾ Minimum value, wetted. ⁽²⁾ Typical values per cm² for alcohol/isopropanol.

Order Information

Order Number	Pore Size (*) (µm)	Diameter (mm)	Sterile	Quantity/Box
MPP020013H	0.2	13	NO	100
MPP020025H	0.2	25	NO	100
MPP020047H	0.2	47	NO	100
MPP020050H	0.2	50	NO	100
MPP020090T	0.2	90	NO	25
MPP020142T	0.2	142	NO	25
MPP045013H	0.45	13	NO	100
MPP045025H	0.45	25	NO	100
MPP045047H	0.45	47	NO	100
MPP045050H	0.45	50	NO	100
MPP045090T	0.45	90	NO	25
MPP045142T	0.45	142	NO	25

(*) Also available in other pore sizes between 0.1 and 20 µm under request.

2.1.12 MPE Polyethersulfone (PES) membrane filters

This strong micro-porous film membrane is constructed from a high temperature polyethersulfone polymer that is acid and base resistant.

These membrane filters are recommended for aqueous solutions biological applications and protein filtration.

They are designed to remove particulates during general filtration and their low protein and drug binding characteristics make them ideally suited for use in life science applications.

Excellent flow speed, even with viscous liquids

They are supplied as standard in pore size 0.2 and 0.45 μm , and in different 6 diameters.

Features

Made entirely from Polyethersulfone (PES)

Hydrophilic membrane

Very low non-specific adsorption

Low drug and protein binding

Low extractables

Sterilisation: by autoclaving at 121°C, with γ -radiation, or ethylene oxide

Applications

Protein and enzyme filtration and sterilization

Sterilisation of biological fluids, serum and tissue culture media

Biological and clinical analysis

Filtration and sterilisation of pharmaceutical solutions

Legionella isolation according to ISO 11731:2017

Technical Specifications

Pore Size	0.2 μm	0.45 μm
Bubble point ⁽¹⁾	3.5 bar	2.6 bar
Flow rates ⁽²⁾	25 ml/min/cm ² /bar	35 ml/min/cm ² /bar
Filter diameter	13 mm, 25 mm, 47 mm, 50 mm, 90 mm, 142 mm. (Other diameter sizes available under request)	
Material	Polyethersulfone (PES)	
Thickness average	Between 110 μm and 150 μm according to different pore size	
Sterilization	By autoclaving at 121°C, with γ -radiation, or ethylene oxide	
Chemical compatibility	See chemical compatibility table	
Extractables	< 2% (< 0.015 mg/cm ²)	

⁽¹⁾ Minimum value, wetted with water. ⁽²⁾ Typical values per cm² for water.

Order Information

Order Number	Pore Size (*) (μm)	Diameter (mm)	Sterile	Quantity/Box
MPE020013H	0.2	13	NO	100
MPE020025H	0.2	25	NO	100
MPE020047H	0.2	47	NO	100
MPE020047H-S	0.2	47	YES	100
MPE020050H	0.2	50	NO	100
MPE020090T	0.2	90	NO	25
MPE020142T	0.2	142	NO	25
MPE045013H	0.45	13	NO	100
MPE045025H	0.45	25	NO	100
MPE045047H	0.45	47	NO	100
MPE045050H	0.45	50	NO	100
MPE045090T	0.45	90	NO	25
MPE045142T	0.45	142	NO	25

(*) Also available in other pore sizes between 0.03 and 5 μm under request.

2.2 Syringe filters

CHMLAB offers a wide range of syringe filters designed to provide efficient and fast filtration of organic and aqueous solutions.

With a wide range of membranes (Cellulose Acetate, Nylon, Regenerated Cellulose, Mixed Cellulose Esters, PTFE, PVDF, PP, PES and glass micro-fiber), pore sizes (0.2, 0.45, 0.65, 0.8, 1, 1.2, 3 and 5) and diameters (4, 13 and 25), and with sterile and non-sterile versions, the syringe filters cover most of the applications in laboratories for pharma, biotechnology, agricultural, food, environmental analysis, etc.

We have designed our syringe filters to provide a fast, efficient, effective and easy filtration. CHM® syringe filters are the best choice to raise your filtration standards.

CHM® syringe filter are printed with membrane type, pore size and batch number to ensure its traceability. The choice of the diameter depends on the volume to be filtered and the charge of particles:

Approximate volumes:

vol. <1 ml - Ø 4 mm

vol. <15 ml - Ø 13 mm

vol. <100 ml - Ø 25 mm

2.2.1 SCA Cellulose acetate syringe filters

SCA Cellulose Acetate syringe filters are designed for quick and efficient filtration for up to 100 ml of liquid.

Ready-to-use units, offer high flow rates at low inlet pressures, presented in 5 pore sizes: 0.2, 0.45, 0.8, 1.2 and 5 µm and in 2 diameters: 13 and 25 mm, to fulfil your filtration requirements for clarifying/ultra cleaning.

They are supplied in sterile and non-sterile versions.

Features

Hydrophilic membrane

Low protein binding

High throughput

Superior strength and stability

Up to 100 ml of sample

Applications

Sample preparation of biological fluids

Protein and enzyme filtration

Cell culture filtration

Clarification of aqueous and alcohol solution

Technical Specifications

Pore Size	0.2 µm	0.45 µm	0.8 µm	1.2 µm	5 µm
Bubble point	3.2 bar	2.0 bar	0.8 bar	0.7 bar	0.4 bar
Flow rates ⁽¹⁾	60 ml/min	180 ml/min	350 ml/min	400 ml/min	500 ml/min
Filter diameter	13 mm, 25 mm				
Filtration area	5.3 cm ² (25 mm)				
Hold-up volume	< 10 µl (13 mm), < 120 µl (25 mm)				
Limits for use	Max. operating pressure: 4.5 bar Burst pressure: 6 bar Max. Temperature 50 °C				
Material	Cellulose Acetate membrane Polypropylene housing (Non sterile)/Acrylic housing (sterile)				
Connectors	PP Housing: Female Luer lock inlet/Luer slip outlet Acrylic Housing: Female Luer lock inlet/Male Luer lock outlet				

⁽¹⁾ Typical values per cm² for water.

Order Information

Order Number	Pore Size (µm)	Diameter (mm)	Sterile	Quantity/Box (*)
SCA020015K-S	0.2	13	YES	50
SCA020015H	0.2	13	NO	100
SCA020015Q	0.2	13	NO	500
SCA020025K-S	0.2	25	YES	50
SCA020025H	0.2	25	NO	100
SCA020025Q	0.2	25	NO	500
SCA045015K-S	0.45	13	YES	50
SCA045015H	0.45	13	NO	100
SCA045015Q	0.45	13	NO	500
SCA045025K-S	0.45	25	YES	50
SCA045025H	0.45	25	NO	100
SCA045025Q	0.45	25	NO	500
SCA080015K-S	0.8	13	YES	50
SCA080015H	0.8	13	NO	100
SCA080015Q	0.8	13	NO	500
SCA080025K-S	0.8	25	YES	50
SCA080025H	0.8	25	NO	100
SCA080025Q	0.8	25	NO	500
SCA120015K-S	1.2	13	YES	50
SCA120015H	1.2	13	NO	100
SCA120015Q	1.2	13	NO	500
SCA120025K-S	1.2	25	YES	50
SCA120025H	1.2	25	NO	100
SCA120025Q	1.2	25	NO	500
SCA500015K-S	5	13	YES	50
SCA500015H	5	13	NO	100
SCA500015Q	5	13	NO	500
SCA500025K-S	5	25	YES	50
SCA500025H	5	25	NO	100
SCA500025Q	5	25	NO	500

(*) Pack of 1000 syringe filters is also available under request in all pore sizes.

2.2.2 SNY Polyamide 66 (Nylon) syringe filters

SNY syringe filters offer a Polyamide 66 (Nylon) membrane in a polypropylene housing.

Due to their high chemical compatibility and physical strength, these syringe filters are recommended for clarifying and sterilizing HPLC samples.

They are supplied in two different pore sizes, 0.2 and 0.45 μm , and in three diameters 4, 13 and 25 mm.

Features

Hydrophilic membrane

Wide chemical compatibility range

Autoclavable

Applications

Filtration and clarification of samples

Sterilization of aqueous and dilute organic solvents

HPLC sample preparation

Technical Specifications

Pore Size	0.2 µm	0.45 µm
Bubble point ⁽¹⁾	3.4 bar	2.0 bar
Flow rates ⁽²⁾	20 ml/min (13 mm), 75 ml/min (25 mm)	40 ml/min (13 mm), 150 ml/min (25 mm)
Filter diameter	4 mm, 13 mm, 25 mm	
Filtration area	0.12 cm ² (4 mm), 1.32 cm ² (13 mm), 4.8 cm ² (25 mm)	
Hold-up volume	< 1µl (4 mm), < 10µl (13 mm), < 120µl (25 mm)	
Limits for use	Max. operating pressure: 4.5 bar Burst pressure: 6 bar Max. Temperature 121 °C/ 30 min (autoclavable)	
Material	Polyamide 66 (Nylon) membrane Polypropylene housing	
Connectors	Female Luer lock inlet, Luer slip outlet	

⁽¹⁾ Minimum value, wetted with water.

⁽²⁾ Typical values per cm² for water.

Order Information

Order Number	Pore Size (*) (µm)	Diameter (mm)	Sterile	Quantity/Box
SNY020004H	0.2	4	NO	100
SNY020004Q	0.2	4	NO	500
SNY020015H	0.2	13	NO	100
SNY020015Q	0.2	13	NO	500
SNY020015M	0.2	13	NO	1000
SNY020025H	0.2	25	NO	100
SNY020025Q	0.2	25	NO	500
SNY020025M	0.2	25	NO	1000
SNY045004H	0.45	4	NO	100
SNY045004Q	0.45	4	NO	500
SNY045015H	0.45	13	NO	100
SNY045015Q	0.45	13	NO	500
SNY045015M	0.45	13	NO	1000
SNY045025H	0.45	25	NO	100
SNY045025Q	0.45	25	NO	500
SNY045025M	0.45	25	NO	1000

(*) Also available in other pore sizes under request.

2.2.3 SRC Regenerated cellulose syringe filters

SRC units contain hydrophilic and Regenerated Cellulose membranes.

These CHM® ready-to-use syringe filter units are resistant to a wide range of solvents for simple, rapid and reliable ultra-cleaning of small-volume samples for HPLC or GC analysis.

They are supplied in two different pore sizes, 0.2 and 0.45 µm, and in three diameters: 4, 13, and 25 mm.

Features

Hydrophilic membrane

Suitable for aqueous solutions and organic solvents

Low protein adsorption

Autoclavable

Applications

Filtration of aqueous and organic solutions

Sample preparation for HPLC and GC

Clarification

Technical Specifications

Pore Size	0.2 µm			0.45 µm		
Bubble point ⁽¹⁾	> 3.4 bar			> 2.0 bar		
Flow rates ⁽²⁾	a) for hexane					
	3.5 ml/min, 4 mm	140 ml/min, 13 mm	230 ml/min, 25 mm	10 ml/min, 4 mm	280 ml/min, 13 mm	430 ml/min, 25 mm
	b) for methanol					
	1.5 ml/min, 4 mm	55 ml/min, 13 mm	160ml/min, 25 mm	3 ml/min, 4 mm	105 ml/min, 13 mm	325 ml/min, 25 mm
	c) for water					
	0.5 ml/min, 4 mm	10 ml/min, 13 mm	60 ml/min, 25 mm	1.5 ml/min, 4 mm	30 ml/min, 13 mm	100 ml/min, 25 mm
Filter diameter	4 mm, 13 mm, 25 mm					
Filtration area	0.07 cm ² (4 mm) 1.7 cm ² (13 mm) 4.8 cm ² (25 mm)					
Limits for use	Max. operating pressure: 4.5 bar Burst pressure: 6 bar Max. Temperature 121 °C, 30 min (autoclavable)					
Hold-up volume	< 1µl (4 mm), < 10µl (13 mm), < 120µl (25 mm)					
Materials	Regenerated Cellulose membrane Polypropylene housing					
Connectors	Female Luer lock inlet, Luer Slip outlet					

⁽¹⁾ Minimum value, wetted with water.

⁽²⁾ Typical values per cm² for hexane, methanol and water.

Order Information

Order Number	Pore Size (µm)	Diameter (mm)	Sterile	Quantity/Box (*)
SRC020004H	0.2	4	NO	100
SRC020004Q	0.2	4	NO	500
SRC020015H	0.2	13	NO	100
SRC020015Q	0.2	13	NO	500
SRC020025H	0.2	25	NO	100
SRC020025Q	0.2	25	NO	500
SRC045004H	0.45	4	NO	100
SRC045004Q	0.45	4	NO	500
SRC045015H	0.45	13	NO	100
SRC045015Q	0.45	13	NO	500
SRC045025H	0.45	25	NO	100
SRC045025Q	0.45	25	NO	500

(*) Pack of 1000 syringe filters is also available under request in all pore sizes.

2.2.4 STF PTFE/H Hydrophobic syringe filters

Hydrophobic PTFE/H syringe filters are indicated to clean small volume samples for HPLC or GC analysis, where higher chemical resistance is required than offered by SRC (Regenerated cellulose).

They are supplied as standard in two different pore sizes, 0.2 and 0.45 μm , and in three diameters: 4, 13 and 25 mm.

Features

Hydrophobic membrane

High chemical resistance to most solvents and acids

Autoclavable

Applications

Filtration of strong acids and aggressive solutions

Cleaning of small volume samples for HPLC or GC application which require greater chemical resistance than regenerated cellulose syringe filters

Venting applications

Degassing solvents

Phase separation

Filtration of gases

Sterile venting in manual pipettes



Technical Specifications

Pore Size	0.2 µm		0.45 µm		
Bubble point ⁽¹⁾	> 1.4 bar		> 0.9 bar		
Flow rates ⁽²⁾	a) for ethanol				
	20 ml/min, 13 mm	70ml/min, 25 mm	2.0 ml/min, 4 mm	45 ml/min, 13 mm	130 ml/min, 25 mm
	b) for methanol				
	55 ml/min, 13 mm	160ml/min, 25 mm	4.5 ml/min, 4 mm	150 ml/min, 13 mm	260 ml/min, 25 mm
	c) for air				
	0.5 ml/min, 13 mm	1.2 ml/min, 25 mm	0.06 ml/min, 4 mm	1.1 ml/min, 13 mm	1.8 ml/min, 25 mm
Filter diameter	4 mm, 13 mm, 25 mm				
Filtration area	0.07 cm ² (4 mm) 1.7 cm ² (13 mm) 4.8 cm ² (25 mm)				
Limits for use	Max. operating pressure: 4.5 bar Burst pressure: 6 bar Max. Temperature 121 °C, 30 min (autoclavable)				
Hold-up volume	< 1µl (4 mm), < 10µl (13 mm), < 120µl (25 mm)				
Materials	Polytetrafluoroethylene Hydrophobic membrane Polypropylene housing				
Connectors	Female Luer lock inlet, Luer Slip outlet				

⁽¹⁾ Minimum value, wetted with water.

⁽²⁾ Typical values per cm² for ethanol, methanol and air at 1 bar.

Order Information

Order Number	Pore Size (*) (µm)	Diameter (mm)	Sterile	Quantity/Box
STF020004H/H	0.2	4	NO	100
STF020004Q/H	0.2	4	NO	500
STF020015H/H	0.2	13	NO	100
STF020015Q/H	0.2	13	NO	500
STF020015M/H	0.2	13	NO	1000
STF020025H/H	0.2	25	NO	100
STF020025Q/H	0.2	25	NO	500
STF020025M/H	0.2	25	NO	1000
STF045004H/H	0.45	4	NO	100
STF045004Q/H	0.45	4	NO	500
STF045015H/H	0.45	13	NO	100
STF045015Q/H	0.45	13	NO	500
STF045015M/H	0.45	13	NO	1000
STF045025H/H	0.45	25	NO	100
STF045025Q/H	0.45	25	NO	500
STF045025M/H	0.45	25	NO	1000

(*) Also available in other pore sizes under request.

2.2.5 STF PTFE/L Hydrophilic syringe filters

Hydrophilic PTFE/L syringe filters are suitable for aqueous and aggressive organic solvent-based solutions and especially ideal for HPLC operations.

The modified membrane exhibits broad chemical resistance and unsurpassed temperature stability to address aggressive sample matrixes and extreme temperature situations.

There is no need for pre-treatment of the membrane prior to use with aqueous samples.

Features

Hydrophilic membrane

Low protein binding membrane

Maximal chemical and pH resistance

High flow rates

Low levels of ionic extractables

Applications

Filtration of HPLC samples and mobile phases

Filtration of organic solvents with strong chemical causticity

General sample preparation prior to analytical analysis

Clarification of aqueous & organic solutions

Dissolution sample analysis



Technical Specifications

Pore Size	0.2 µm		0.45 µm		
Bubble point ⁽¹⁾	4 bar		2.7 bar		
Flow rates ⁽²⁾	a) for ethanol				
	20 ml/min, 13 mm	70 ml/min, 25 mm	2.0 ml/min, 4 mm	45 ml/min, 13 mm	130 ml/min, 25 mm
	b) for methanol				
	55 ml/min, 13 mm	160ml/min, 25 mm	4.5 ml/min, 4 mm	150 ml/min, 13 mm	260 ml/min, 25 mm
	c) for air				
	0.5 ml/min, 13 mm	1.2 ml/min, 25 mm	0.06 ml/min, 4 mm	1.1 ml/min, 13 mm	1.8 ml/min, 25 mm
Filter diameter	4 mm, 13 mm, 25 mm				
Filtration area	0.07 cm ² (4 mm) 1.7 cm ² (13 mm) 4.8 cm ² (25 mm)				
Limits for use	Max. operating pressure: 4.5 bar Burst pressure: 6 bar Max. Temperature: 121 °C, 30 min (autoclavable)				
Hold-up volume	< 1µl (4 mm), < 10µl (13 mm), < 120µl (25 mm)				
Materials	Hydrophilic Polytetrafluoroethylene Polypropylene housing				
Connectors	Female Luer lock inlet, Luer Slip outlet				

⁽¹⁾ Minimum value, wetted with water.

⁽²⁾ Typical values per cm² for ethanol, methanol and air at 1 bar.

Order Information

Order Number	Pore Size (*) (µm)	Diameter (mm)	Sterile	Quantity/Box
STF010025H/L	0.1	25	NO	100
STF010025Q/L	0.1	25	NO	500
STF010025M/L	0.1	25	NO	1000
STF020004H/L	0.2	4	NO	100
STF020004Q/L	0.2	4	NO	500
STF020015H/L	0.2	13	NO	100
STF020015Q/L	0.2	13	NO	500
STF020015M/L	0.2	13	NO	1000
STF020025H/L	0.2	25	NO	100
STF020025Q/L	0.2	25	NO	500
STF020025M/L	0.2	25	NO	1000
STF045004H/L	0.45	4	NO	100
STF045004Q/L	0.45	4	NO	500
STF045015H/L	0.45	13	NO	100
STF045015Q/L	0.45	13	NO	500
STF045015M/L	0.45	13	NO	1000
STF045025H/L	0.45	25	NO	100
STF045025Q/L	0.45	25	NO	500
STF045025M/L	0.45	25	NO	1000

(*) Also available in other pore sizes under request.

2.2.6 SPP Polypropylene syringe filters

SPP units contain Polypropylene (PP) membranes.

Due to their broad chemical compatibility, these CHM® ready-to-use syringe filters can be used with aqueous and organic solvents.

They have low extractable levels to provide accurate and consistent analysis results for sensitive ion chromatography applications.

These polypropylene syringe filters are used in HPLC where detection levels are below 230 nm.

They are supplied in two pore sizes 0.2 and 0.45 μm , and in two diameters 13 and 25 mm.

Features

Broad chemical compatibility

Hydrophilic membrane

Negligible protein binding

Applications

Filtration of aqueous and organic solvents

HPLC applications. Detection levels < 230 nm

Ion chromatography

Total digest for heavy metals

Technical Specifications

Pore Size	0.2 µm	0.45 µm
Filter diameter	13 mm, 25 mm	
Filtration area	1.3 cm ² (13 mm) 4.6 cm ² (25 mm)	
Limits for use	Max. operating pressure: 4.5 bar Burst pressure: 6 bar Max. Temperature: 131 °C, 121 °C, 30 min (autoclavable)	
Hold-up volume	< 10 µl (13 mm), < 120 µl (25 mm)	
Material	Polypropylene membrane Polypropylene housing	
Connectors	Female Luer Lock inlet, Luer slip outlet	

Order Information

Order Number	Pore Size (µm)	Diameter (mm)	Sterile	Quantity/Box
SPP020015H	0.2	13	NO	100
SPP020015Q	0.2	13	NO	500
SPP020025H	0.2	25	NO	100
SPP020025Q	0.2	25	NO	500
SPP020025M	0.2	25	NO	1000
SPP045015H	0.45	13	NO	100
SPP045015Q	0.45	13	NO	500
SPP045025H	0.45	25	NO	100
SPP045025Q	0.45	25	NO	500
SPP045025M	0.45	25	NO	1000

2.2.7 SPV/L Hydrophilic polyvinylidene fluoride (PVDF/L) syringe filters

SPV/L units contain Hydrophilic Polyvinylidene Fluoride (PVDF/L) membranes.

These CHM® ready-to-use syringe filter units are ideal for sterilizing and clarifying filtration of biological solutions.

They are compatible with a wide range of solvents, even with aggressive acids and alcohols.

Also available in individual sterile peel-pack.

They are supplied as standard in two different pore sizes, 0.2 and 0.45 µm, and in three diameters: 4, 13 and 25 mm.

Features

Hydrophilic membrane

Low protein adsorption

High binding capacity

Excellent chemical compatibility

High flow rates

Autoclavable

Applications

Filtration of aqueous and organic solutions

Sterilization of aggressive and non-aggressive solvent-based mobile phases

Sterilizing and clarifying filtration of biological solutions

Chromatography

Protein sequencing

Technical Specifications

Pore Size	0.2 µm	0.45 µm
Bubble point ⁽¹⁾	3.45 bar	1.6 bar
Filter diameter	4 mm, 15 mm, 25 mm	
Filtration area	0.7 cm ² (4 mm) 1.7 cm ² (13 mm) 4.5 cm ² (25 mm)	
Hold-up volume	< 1 µl (4 mm), < 10 µl (13 mm), < 120 µl (25 mm)	
Limits for use	Max. operating pressure: 4.5 bar Burst pressure: 6 bar Max. Temperature: 45 °C	
Materials	Hydrophilic Polyvinylidene fluoride membrane Polypropylene housing (non-sterile)/Acrylic housing (sterile)	
Connectors	PP Housing: Female Luer Lock inlet/Luer slip outlet Acrylic housing: Female Luer Lock inlet/Male Luer Lock outlet	

⁽¹⁾ Minimum value, wetted with water.

Order Information

Order Number	Pore Size (µm)	Diameter (mm)	Sterile	Quantity/Box
SPV020004H/L	0.2	4	NO	100
SPV020004Q/L	0.2	4	NO	500
SPV020015K-S/L	0.2	13	YES	50
SPV020015H/L	0.2	13	NO	100
SPV020015Q/L	0.2	13	NO	500
SPV020015M/L	0.2	13	NO	1000
SPV020025K-S/L	0.2	25	YES	50
SPV020025H/L	0.2	25	NO	100
SPV020025Q/L	0.2	25	NO	500
SPV020025M/L	0.2	25	NO	1000
SPV045004H/L	0.45	4	NO	100
SPV045004Q/L	0.45	4	NO	500
SPV045015K-S/L	0.45	13	YES	50
SPV045015H/L	0.45	13	NO	100
SPV045015Q/L	0.45	13	NO	500
SPV045015M/L	0.45	13	NO	1000
SPV045025K-S/L	0.45	25	YES	50
SPV045025H/L	0.45	25	NO	100
SPV045025Q/L	0.45	25	NO	500
SPV045025M/L	0.45	25	NO	1000

(*) Also available in other pore sizes under request.

2.2.8 SPV/H Hydrophobic polyvinylidene fluoride (PVDF/H) syringe filters

SPV/H units contain Hydrophobic Polyvinylidene Fluoride (PVDF/H) membranes. These CHM® ready-to-use syringe filter units are ideal to filter chemicals and some solvents, to filtrate non-aqueous solutions or process air and gases.

They are supplied in two different pore sizes, 0.2 and 0.45 μm , and in two diameters: 13 and 25 mm.

Features

Hydrophobic membrane

Good chemical stability

Low extractables

Applications

Air/Gas purification

Solvents and chemicals filtration

Venting

High-temperature filtration for units with PP housing

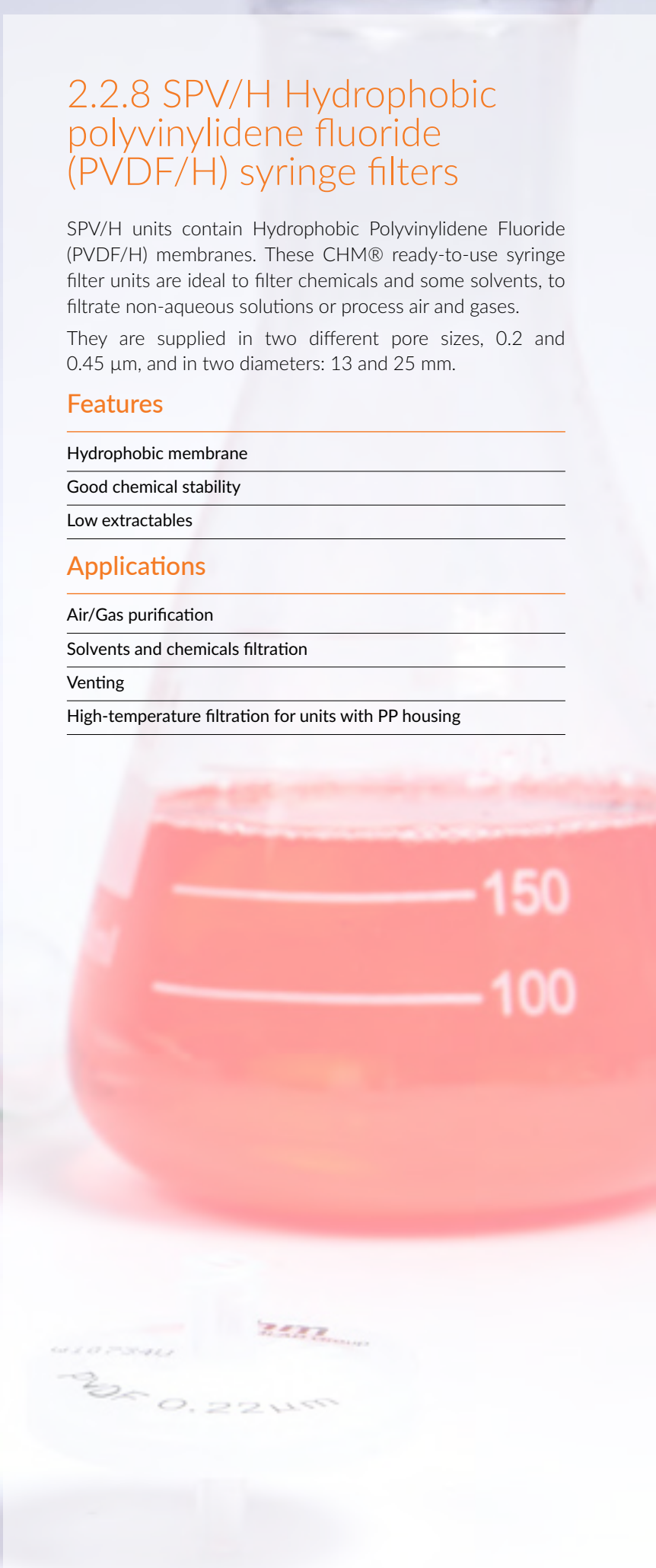

Technical Specifications

Pore Size	0.2 µm	0.45 µm
Bubble point ⁽¹⁾	2.3 bar	1.1 bar
Filter diameter	15 mm, 25 mm	
Filtration area	1.7 cm ² (15 mm) 4.8 cm ² (25 mm)	
Hold-up volume	< 10 µl (13 mm), < 120 µl (25 mm)	
Limits for use	Max. operating pressure: 4.5 bar Burst pressure: 6 bar Max. Temperature: 45 °C (Acrylic), 80 °C (PP)	
Materials	Hydrophobic PVDF membrane Polypropylene housing (Non sterile)/Acrylic housing (Sterile)	
Connectors	PP Housing: Female Luer Lock inlet/Luer slip outlet	

⁽¹⁾ Minimum value, wetted with water.

Order Information

Order Number	Pore Size (µm)	Diameter (mm)	Sterile	Quantity/Box
SPV020015K-S/H	0.2	15	YES	50
SPV020015H/H	0.2	15	NO	100
SPV020015Q/H	0.2	15	NO	500
SPV020025K-S/H	0.2	25	YES	50
SPV020025H/H	0.2	25	NO	100
SPV020025Q/H	0.2	25	NO	500
SPV045015K-S/H	0.45	15	YES	50
SPV045015H/H	0.45	15	NO	100
SPV045015Q/H	0.45	15	NO	500
SPV045025K-S/H	0.45	25	YES	50
SPV045025H/H	0.45	25	NO	100
SPV045025Q/H	0.45	25	NO	500

2.2.9 SPE Polyethersulfone (PES) syringe filters

SPE units contain Polyethersulfone (PES) membranes.

These CHM® ready-to-use syringe filter units are designed to remove particles during general filtration. They are ideal to use in life science applications.

Preparation of aqueous, biological or protein-based solutions for chromatography analysis.

Also available in individual sterile peel-pack.

They are supplied in two different pore sizes, 0.2 and 0.45 µm, and in two diameters: 13 and 25 mm.

Features

Hydrophilic membrane

Low protein binding

Fast flow rates

Wide range of chemical compatibility

Not autoclavable. Sterilization only by γ - irradiation or ethylene oxide

Applications

Purification and sterilization of aqueous solutions and/or biological samples

Protein and enzyme filtration sterilization

IC chromatography

Cell culture filtration

Tissue culture media sterilization

Technical Specifications

Pore Size	0.2 µm		0.45 µm	
Bubble point ⁽¹⁾	3.2 bar		1.1 bar	
Flow rates ⁽²⁾	8 ml/min, 13 mm	100 ml/min, 25 mm	12 ml/min, 13 mm	150 ml/min, 25 mm
Filter diameter	13 mm, 25 mm			
Filtration area	1.7 cm ² (13 mm) 4.8 cm ² (25 mm)			
Hold-up volume	< 10 µl (13 mm), < 120 µl (25 mm)			
Limits for use	Max. operating pressure: 4.5 bar Burst pressure: 6 bar (25mm) Max. Temperature: 60 °C			
Materials	Polyethersulfone membrane Polypropylene housing (non-sterile)/Acrylic housing (sterile)			
Connectors	PP Housing: Female Luer Lock inlet/Luer slip outlet Acrylic housing: Female Luer Lock inlet/Male Luer Lock outlet			

⁽¹⁾ Minimum value, wetted with water. ⁽²⁾ Typical values per cm² for water.

Order Information

Order Number	Pore Size (µm)	Diameter (mm)	Sterile	Quantity/Box (*)
SPE020015K-S	0.2	13	YES	50
SPE020015H	0.2	13	NO	100
SPE020015Q	0.2	13	NO	500
SPE020025K-S	0.2	25	YES	50
SPE020025H	0.2	25	NO	100
SPE020025Q	0.2	25	NO	500
SPE045015K-S	0.45	13	YES	50
SPE045015H	0.45	13	NO	100
SPE045015Q	0.45	13	NO	500
SPE045025K-S	0.45	25	YES	50
SPE045025H	0.45	25	NO	100
SPE045025Q	0.45	25	NO	500

(*) Also available packs of 1000 units in all pore sizes.

2.2.10 SCE Mixed cellulose esters syringe filters

SCE units contain Mixed Cellulose Esters (MCE) membranes. These CHM® ready-to-use syringe filter units are designed for fast filtration with high flow rates, mainly for aqueous clarification and particle capture.

They are mainly supplied in two different pore sizes, 0.2 and 0.45 µm (other pore sizes available under request), and in two diameters: 13 and 25 mm.

Features

Hydrophilic membrane

High flow rates

High binding capacity

Uniform pore structure

Applications

Filtration of aqueous samples

Chromatography with aqueous solvents

Clarification

Analytical sample preparation

Technical Specifications

Pore Size	0.2 µm	0.45 µm
Filter diameter	13 mm, 25 mm	
Filtration area	1.7 cm ² (13 mm) 4.8 cm ² (25 mm)	
Hold-up volume	< 10 µl (13 mm), < 120 µl (25 mm)	
Limits for use	Max operating pressure: 4.5 bar Burst pressure: 6 bar Max. Temperature: 45 °C	
Material	Mixed Cellulose Esters membrane Polypropylene housing (non-sterile)/Acrylic housing (sterile)	
Connectors	PP Housing: Female Luer Lock inlet/Luer slip outlet Acrylic housing: Female Luer Lock inlet/Male Luer Lock outlet	

⁽¹⁾ Minimum value, wetted with water.

⁽²⁾ Typical values per cm² for water.

Order Information

Order Number	Pore Size (µm)	Diameter (mm)	Sterile	Quantity/Box (*)
SCE020015K-S	0.2	13	YES	50
SCE020015H	0.2	13	NO	100
SCE020015Q	0.2	13	NO	500
SCE020025K-S	0.2	25	YES	50
SCE020025H	0.2	25	NO	100
SCE020025Q	0.2	25	NO	500
SCE045015K-S	0.45	13	YES	50
SCE045015H	0.45	13	NO	100
SCE045015Q	0.45	13	NO	500
SCE045025K-S	0.45	25	YES	50
SCE045025H	0.45	25	NO	100
SCE045025Q	0.45	25	NO	500

(*) Also available packs of 1000 units in all pore sizes.

2.2.11 SGF Glass microfiber syringe filter

Glass microfiber syringe filter.

SGF syringe filters contain a glass fibre filter with a retention efficiency of 98%.

It is very useful when relatively dirty solutions have to be clarified, or as a pre-filter of 0.2 µm or 0.45 µm SCA.

They are available in 0.45 µm, 1.0 µm, 0.7 µm and 3 µm.

Features

Hydrophilic material

Glass microfiber Acrylic Binder

High flow rates

Not autoclavable.

Sterilization only by gamma irradiation or ethylene oxide

Applications

Filtration of aqueous and organic solutions

Fast filtration of samples with high particle load

Pre-filter of small volume liquids to avoid saturation of small-porosity membranes

Fuel hydraulic fluids and machined parts

Technical Specifications

Retention Range	0.45 µm	0.7 µm	1.0 µm	3 µm
Filter diameter	25 mm			
Filtration area	6.2 cm ²			
Hold-up volume	< 120 µl (25 mm)			
Limits for use	Max. operating pressure: 4.5 bar Burst pressure: 6 bar Max. Temperature: 50 °C			
Materials	Glass microfiber with binders + membrane Polypropylene housing			
Connectors	Female Luer Lock inlet, Luer Slip outlet			

Order Information

Order Number	Retention Range (μm)	Diameter (mm)	Sterile	Quantity/Box
SGF045025H	0.45	25	NO	100
SGF045025Q	0.45	25	NO	500
SGF070025H	0.7	25	NO	100
SGF070025Q	0.7	25	NO	500
SGF100025H	1.0	25	NO	100
SGF100025Q	1.0	25	NO	500
SGF300025H	3.0	25	NO	100
SGF300025Q	3.0	25	NO	500

2.2.12 Glass microfiber pre-filter + membrane syringe filter

Glass microfiber pre-filter combined with membrane filter enhance sample preparation efficiency.

The membrane materials can be, Cellulose Acetate, Nylon, Polyethersulfone (PES) and PTFE. They are combined with glass microfiber prefilter pore size: 1.0 μm .

Membrane porosity: 0.45 μm , filter diameter 25 mm.

Applications

Filtration of aqueous solutions

Filtration of organic solutions

Prefiltration

HPLC, GC and IC chromatography

Filtration of fruit juice samples

Order Information

Order Number	Material	Retention Range + Pore Size (*) (μm)	Diameter (mm)	Sterile	Quantity/ Box (**)
SNY045025H-GF	Glass microfiber prefilter + Nylon membrane	1.00 + 0.45	25	NO	100
SNY045025Q-GF	Glass microfiber prefilter + Nylon membrane	1.00 + 0.45	25	NO	500
STF045025H/L-GF	Glass microfiber prefilter + Hydrophilic PTFE membrane	1.00 + 0.45	25	NO	100
STF045025Q/L-GF	Glass microfiber prefilter + Hydrophilic PTFE membrane	1.00 + 0.45	25	NO	500
SPE045025H-GF	Glass microfiber prefilter + Polyethersulfone membrane	1.00 + 0.45	25	NO	100
SPE045025Q-GF	Glass microfiber prefilter + Polyethersulfone membrane	1.00 + 0.45	25	NO	500
SCA045025H-GF	Glass microfiber prefilter + Cellulose Acetate membrane	1.00 + 0.45	25	NO	100
SCA045025Q-GF	Glass microfiber prefilter + Cellulose Acetate membrane	1.00 + 0.45	25	NO	500

(*) Other combinations available.

(**) Also available packs of 1000 units in all pore sizes.

2.3 Venting filters

SVT venting filters are reusable units that contain a reinforced PTFE membrane with polypropylene support grid, in a polypropylene housing.

These units are easily connected to fermenters, containers or biological reactors.

They can work at high pressure.

The large filtering surface (20 cm²) makes it possible to work at high airflow rates even with a low-pressure differential.

They are supplied in two pore sizes, 0.2 and 0.45 µm.

Features

Hydrophobic membrane

Reusable filter units (at least 10 autoclaving)

Light-weight (approx. 20 g)

High flow rates

Autoclavable

Sterile and non-sterile versions

Applications

Venting of autoclaves

Sterilization of air and gases



Technical Specifications

Pore Size	0.2 µm	0.45 µm
Airflow (1 bar)	27 l/min	32 l/min
Sterilization	Autoclave at 121°C or Ethylene Oxide Autoclave up to 10 times	
Filtration area	20 cm ²	
Filter diameter	50 mm	
Filter housing	62 mm	
Hold-up volume	0,5 ml	
Max. operating pressure	3 bar	
Max. temperature	134 °C	
Materials	Membrane: Reinforced PTFE Housing: Polypropylene	
Connectors	Hose Barb (6-12 mm)	

Order Information

Order Number	Pore Size (µm)	Diameter (mm)	Sterile	Quantity/Box
STF020050T	0.2	50	NO	10
STF020050T-S	0.2	50	YES	10
STF045050T	0.45	50	NO	10
STF045050T-S	0.45	50	YES	10

2.4 BIO-tr@Ns blotting membranes

Blotting membranes are used widely in molecular biology, biotechnology and genetics, as a method of transferring proteins, DNA or RNA.

CHMLAB offers 3 kinds of BIO-tr@ns blotting membranes: nitrocellulose membrane, PVDF transfer membrane and Polyamide 66 (Nylon) membrane.

Selecting the appropriate membrane is critical to the success of a nucleic acid or protein transfer procedure.

The several types of Bio-tr@ns transfer membranes exhibit different performance characteristics which can directly affect the outcome of a specific technique.

We can custom blotting membrane, like the shape, size, contents, package and different use as per your requirements.



2.4.1 BIO-tr@ns pure and supported nitrocellulose membrane

CHMLAB Bio-tr@ns Pure Nitrocellulose membrane is one of the most widely used in analytical and research applications. Minimize amounts of wetting agent and have a lower water-extractable content.

The high sensitivity of pure cellulose nitrate ensures excellent results in all the transfers, especially in protein blotting.

Features

100% Pure Nitrocellulose

For process requiring optimum resolution

Compatible with Chromogenic, Radioactive, Fluorescent detection methods

Excellent strength

No detergents added

Binding Interaction: hydrophobic & electrostatic

Applications

Westerns

Protein & immunoblotting

Northern

Southern

Dot/slot blots

Nucleic acid and protein transfer

CHMLAB Bio-tr@ns Supported Nitrocellulose membrane recommended for DNA/RNA/Protein transfers with procedures requiring rigorous handling.

Features

Supported Nitrocellulose

Multiple reprobing

BSA binding up to 100 µg/cm²

High sensitivities, low backgrounds

Applications

Multiple re-hybridisations

Colony/plaque lifts

Northern

Southern

Dot/slot blots

Biotinylated detection systems

Chemiluminescent detection systems

Order Information

Pore Size	Pure Nitrocellulose		Supported Nitrocellulose	
	0.45 µm	0.20 µm	0.45 µm	0.20 µm
Diameter/size				
50 Circles/Box				
82 mm	BCN045082K	BCN020082K	BCNS045082K	BCNS020082K
85 mm	BCN045085K	BCN020085K	BCNS045085K	BCNS020085K
132 mm	BCN0450132K	BCN020132K	BCNS045132K	BCNS020132K
137 mm	BCN0450137K	BCN020137K	BCNS045137K	BCNS020137K
5 Sheets/Pack				
15 x 15 cm	BCN045150150V	BCN020150150V	BCNS045150150V	BCNS020150150V
20 x 20 cm	BCN045200200V	BCN020200200V	BCNS045200200V	BCNS020200200V
22 x 22 cm	BCN045220220V	BCN020220220V	BCNS045220220V	BCNS020220220V
1 Roll/Pack				
20 cm x 3 m	BCN04520300R	BCN02020300R	BCNS04520300R	BCNS02020300R
30 cm x 3 m	BCN04530300R	BCN02030300R	BCNS04530300R	BCNS02030300R

2.4.2 BIO-tr@ns PVDF membrane

CHMLAB Bio-tr@ns Polyvinylidene Fluoride PVDF membrane has high protein adsorption, so proteins during transfer or reprobing won't be lost.

The open-pore structure makes accessing bound proteins and removing unbound probes easily.

Membranes optimized for fluorescent blots dramatically increase signal for high sensitivity in quantitative, multiplexing applications.

Features

Composition unsupported Polyvinylidene Fluoride

Ideal for protein sequencing

Chemical resistance

No discolouration

Nonflammable

Hydrophilic membrane

BSA binding capacity up to 125 $\mu\text{g}/\text{cm}^2$

Applications

BSA-bovine Serum Aluminie

Western blotting

Binding assays

Amino acid analysis

N-terminal protein sequencing

Dot/slot blotting

Glycoprotein visualization

Lipopolysaccharide analysis

Order Information

Pore Sizes	0.45 μm	0.20 μm
Diameter/size		
	5 Sheets/Box	
15 x 15 cm	BPV045150150V	BPV020150150V
20 x 20 cm	BPV045200200V	BPV020200200V
22 x 22 cm	BPV045220220V	BPV020220220V
	1 Roll/Pack	
20 cm x 3 m	BPV04520300R	BPV02020300R
30 cm x 3 m	BPV04530300R	BPV02030300R

2.4.3 BIO-tr@ns neutral and reprobing charge polyamide 66 (Nylon) membrane

CHMLAB Bio-tr@ns Neutral Polyamide 66 (Nylon). The open-pore structure permits maximum accessibility of target sequences to the probe and allows efficient removal of the unhybridized probe, thereby reducing background.

Features

High strength
 High sensitivity
 Versatile adsorption properties
 Good chemical resistance
 Hydrophilic membrane
 Nucleic acid-binding is 350 µg/cm²

Applications

Colony/plaque lifts
 Dot/slot blotting
 Cell culture
 Clarification of aqueous solutions
 Chromogenic, radioactive, fluorescent detection systems
 Northern
 Southern
 Protein binding
 Microarrays
 Macroarrays

CHMLAB Bio-tr@ns Reprobing Charged Polyamide 66 (Nylon) is an inherently charged nylon membrane, specifically designed to allow for numerous reproblings.

Features

Positively Supported charged Polyamide 66 (Nylon) membrane
 Nucleic acid-binding is 450 µg/cm²
 Provide consistent results through 12 or more reproblings

Applications

Northern
 Southern
 Radiolabelled and non-radiolabelled detection systems
 Multiple reproblings
 UV crosslinking
 Alkaline blotting

Order Information

Pore Sizes	Nylon	Nylon Reprobing Charged
	0.45 µm	0.20 µm
Diameter/size	50 Circles/Box	
82 mm	BNY045082K	BNYR020082K
85 mm	BNY045085K	BNYR020085K
132 mm	BNY045132K	BNYR020132K
137 mm	BNY045137K	BNYR020137K
	5 Sheets/Pack	
15 x 15 cm	BNY045150150V	BNYR020150150V
20 x 20 cm	BNY045200200V	BNYR020200200V
22 x 22 cm	BNY045220220V	BNYR020220220V
	1 Roll/Pack	
20 cm x 3 m	BNY04520300R	BNYR02020300R
30 cm x 3 m	BNY04530300R	BNYR02030300R

2.5 Microbiological monitors

CHM® Biofun sterile microbiological monitors are designed to be used in the membrane filtration technique to recover microorganisms from aqueous samples.

Each monitor is a single-use, pre-sterilized filtering unit consisting of a measured filter funnel, base, pad, membrane, removable lid and plug.

The all-in-one sterile construction of these microbiological filter funnels makes them ideal for microbiological analysis.

These ready-to-use 100 ml units are suited for monitoring contaminants in all types of aqueous samples and they are specifically designed for the detection and enumeration of microorganisms in pharmaceuticals, cosmetics, food, beverages, water and other liquids.

Filtration unit easily converts to a Petri dish, which can be labelled and incubated for culturing.

No flaming required and with no need to sterilize funnels or filter base between samples, testing time can be reduced by up to 70%.

Reduced contamination thanks to the single-use materials that virtually eliminate cross-contamination between funnel and membrane.

All-in-one filtration units reduce the chance of external error and make reproducible results due to this reduction.

Biofun® M100 Monitors are ready to use filter units designed to be placed onto the bases of a vacuum manifold.

Funnel adaptors onto bases are provided in each box. All units are supplied sterile and individually wrapped.

Features and Benefits

All-in-one system

Rapid testing. Testing time can be reduced by up to 70%

No flaming required: minimizes the risk of cross-contamination

Reduced contamination

Reproducible results

Easy handling

Applications

Microbiological analysis of:

Water (potable and waste)

Soft drinks

Dairy products

Beer

Wine

Order Information

Order Number	Membrane Type (*)	Capacity (ml)	Pore Size (µm)	Diameter (mm)	Sterile	Units/Box
M100-MNW020047K-SG	White MCE gridded membrane with pad	100	0.2	47	YES	50
M100-MNW020056K-SG	White MCE gridded membrane	100	0.2	56	YES	50
M100-MNW045047K-SG	White MCE gridded membrane with pad	100	0.45	47	YES	50
M100-MNW045056K-SG	White MCE gridded membrane	100	0.45	56	YES	50
M100-MNW080047K-SG	White MCE gridded membrane with pad	100	0.8	47	YES	50
M100-MNB020047K-SW	Black MCE gridded membrane with pad	100	0.2	47	YES	50
M100-MNB045047K-SW	Black MCE gridded membrane with pad	100	0.45	47	YES	50
M100-MNB045056K-SW	Black MCE gridded membrane	100	0.45	56	YES	50
M100-MNB080047K-SW	Black MCE gridded membrane with pad	100	0.8	47	YES	50
M100-MNB080056K-SW	Black MCE gridded membrane	100	0.8	56	YES	50
M100-ADAP	Adaptor to connect 47 mm Microbiological monitors to CHM® Stainless steel Manifolds					

(*) Absorbent cardboard



2.6 Membrane hardware

2.6.1 1-, 3- and 6-branch CHM®FR manifold

CHM®FR manifolds allow independent usage of any port with a stopcock.

They have been designed specifically for applications in which the particles or microorganisms retained on the membrane filter surface area of interest.

The manifolds are made of high quality AISI 316 stainless steel and are available with 1, 3 and 6 filtration funnels, and in 100 ml and 500 ml capacity funnels.

In the 3 or 6 branch units, due to the stainless steel taps on the manifold ports, the vacuum for each holder can be turned on and off individually. The stainless steel frit ensures a homogenous distribution of the particles on the membrane filter surface.

Highly polished surface facilitates easy and efficient cleaning and rinsing.



Order Information

Order Number	Branches	Funnel Capacity
FR1X100MC	1	100 ml
FR1X500MC	1	500 ml
FR3X100MC	3	100 ml
FR3X500MC	3	500 ml
FR6X100MC	6	100 ml
FR6X500MC	6	500 ml

Funnel and filter support can be autoclavable and flame sterilisable.

Technical Specifications

Max. Filtration Area	12.5 cm ²
Materials	AISI 316 Stainless steel manifold, funnels, lids, clamps, PTFE bearing balls and filter supports Vitton® flat gaskets Vitton® sealing rings for lid, cap and hose nipple connector
Membrane filter	47 / 50 mm diameter
Sterilization	By autoclaving at (121 °C or 134 °C) or dry heat (180 °C) Sanitization with flaming

Vacuum Pumps

Order Information	Recommended for Manifold	Max Flow (l/min) Rate
VP300IP25	1- 3- branches	25
VP800FL59	6- branches	59



2.6.2 Filter holders

2.6.2.1 Glass filtration system

These versatile all-glass filter holders are supplied with a glass frit filter support. It ensures the uniform distribution of retained particles on the filter surface.

Recommended for colony counting and collection of suspended solids.

The system composed of glass funnel and base with vacuum connector and receiving flask is supplied with: ground glass outer and inner joints to connect to the receiving glass or with silicon stopper connector.

Order Information

Order Number	Description
FS047300T	Glass filtration system for 47 mm (or 50 mm) membranes with stopper
FS047300S	Glass filtration system for 47 mm (or 50 mm) membranes without stopper
FS047250P	Polycarbonate filtration system for 47 mm (or 50 mm)



2.6.2.2 Polycarbonate filtration system

The Polycarbonate filtration system is composed with a top part of 250 ml which allows to make vacuum and optionally with a receiver flask of 250 ml. It is all together a practical system for the filtration, in and outside the laboratory.

It is generally used for the clarification or sterile filtration of up to about 200 ml volumes of aqueous solutions.

Type FS047250P is complete with top part and receiver flask, and type FS047250W does not include the 250 ml receiver flask.

Suitable for membrane filter diameter 47 mm (prefilter 37 mm)

Technical Specifications

Filtration Area	12.5 cm ²
Max. Operating Pressure	2 bar
Chemical compatibility	As for polycarbonate, polypropylene and silicone
Sterilization	By autoclaving at 121°C
Top part capacity	250 ml
Receiver flask capacity	250 ml

Order Information

Order Number	Description
FS047250P	Polycarbonate holder for 47 mm membrane filter with 250 ml top part and receiver flask, for vacuum or pressure filtration (Complete system)
FS047250W	Polycarbonate holder for 47 mm membrane filter, with 250 ml top part, for vacuum filtration (Receiver flask not included)



2.6.2.3 Stainless steel vacuum filtration support

Individual filter holder, stand-alone, to be assembled on vacuum flasks.

This stainless-steel support ensures homogeneous distribution of the residues on the membrane filter surface.

It is supplied in 2 versions: 100 or 500 ml stainless steel funnels.

Easy to use.

Indicated for 47 or 50 mm membrane filters.

Applications

Environmental Testing

Water Testing

Food and Beverage

Technical Specifications

Membrane Filter Diameter	47/50 mm
Filtration Area	12.5 cm ²
Chemical Compatibility	According to Stainless steel and Viton®
Sterilization	By autoclaving (max. 134 °C) By dry heat (max. 180 °C) By flaming
Outlet Spout	10 mm
Funnel capacity	100 ml, 500 ml
Materials	Stainless steel and Viton® gaskets
Parts included	Lid, funnel, base part, filter support, clamp and tap made of stainless steel; Viton® flat gasket, Viton® lid seal
Number of filter support	1

Order Information

Order Number	Funnel capacity	Units
FR1X100IN	100 ml	1
FR1X500IN	500 ml	1



2.6.2.4 Stainless steel filter holder

CHM® HIN inox holder for solvents and chemicals.

The PTFE-coated surface on the top part is an important property of the filter holder and ensures leak-proof sealing without a sealing ring.

The temperature resistance is extremely good, and the chemical compatibility depends only on the used membrane filter type.

Sterilization: by autoclaving (max. 134 °C) or by dry heat (max. 180 °C).

The top part can easily be mounted on the bottom part using the tightening tool supplied.

The filter supports in the top and bottom parts allow filtration in either direction.

Technical Specifications

Membrane Filter Diameter	25 mm	47 mm (in line)
Filtration area	3 cm ²	13 cm ²
Max. operating pressure	7 bar	20 bar
Chemical compatibility	The same as stainless steel and PTFE	
Sterilization	By autoclaving (max 134 °C) or by dry heat (max 180 °C)	
Connectors	Male Luer Lock inlet, Luer slip outlet	Hose nipples DN10

Order Information

Order Number	Material	Diameter (mm)	Quantity/Pack
HIN025001	INOX	25	1
HIN047001	INOX	47	1
HIN090001	INOX	90	1
HIN142001	INOX	142	1



2.6.2.5 Polycarbonate filter holder

CHM® HPC Polycarbonate holder for aqueous solutions.

This CHM® HPC filter holder is made of stable polycarbonate and contains a silicone gasket for leak-proof sealing.

The polycarbonate material withstands numerous working and washing cycles. It can be sterilized by autoclaving (max. 121°C).

The filter supports in the top and bottom parts allow filtration in either direction. The holder has excellent resistance to pressure; up to 7 bar of operating pressure. The transparent top part allows the visual control of the correct fit.

Technical Specifications

Membrane Filter Diameter	13 mm	25 mm	47 mm (in line)
Filtration area	0.5 cm ²	3 cm ²	12.5 cm ²
Max. operating pressure	7 bar		
Materials	Polycarbonate top and bottom parts Silicone gasket		
Chemical compatibility	The same as Polycarbonate and Silicone		
Sterilization	By autoclaving (max 121 °C)		
Connectors	Male Luer Lock inlet, Luer slip outlet		Inlet and outlet M12 tube connection

Order Information

Order Number	Material	Diameter (mm)	Quantity/Pack
HPC013002	Polycarbonate	13	2
HPC013010	Polycarbonate	13	10
HPC025002	Polycarbonate	25	2
HPC025010	Polycarbonate	25	10
HPC047001	Polycarbonate	47/50	1
HPC047005	Polycarbonate	47/50	5



2.6.2.6 PTFE filter holder

CHM® HTF filter holder for organic solvents and aggressive chemicals. Made completely of PTFE, this holder has broad chemical compatibility and contains no trace elements which could be released into the liquid being filtered. Easy cleaning. Autoclavable by dry heat at 180°C.

It is indicated for particle removal from samples and reagents for analytical methods. The construction of the holder ensures leak-proof sealing without a sealing ring, and avoids twisting of the membrane filter when the top is tightened onto the base.

Technical Specifications

Membrane Filter Diameter	13 mm
Filtration area	0.5 cm ²
Max. operating pressure	5 bar
Materials	PTFE top and bottom parts
Chemical compatibility	The same as PTFE
Sterilization	By autoclaving (max 134 °C) or by dry heat (max 180 °C)
Connectors	Male Luer Lock inlet, Luer slip outlet

Order Information

Order Number	Material	Diameter (mm)	Quantity/Pack
HTF013001	PTFE	13	1

2.6.3 Membrane dispenser

The membrane filter dispenser meets all requirements placed on advanced laboratory equipment.

This membrane dispenser is designed for individually sterile-packaged cellulose nitrate membranes packed in pleated boned. Each membrane box contains 300 membrane filters individually sealed on a special pleated band, and its design makes it easy to open and seal for storage.

Thanks to the special pack, the dispenser makes each membrane quickly and reliably accessible; avoids filter band slippage or even damaged membranes.

Features

Compact and robust design

Easy insertion of the membrane bonds, even without having a complete membrane package

The control system prevents unwanted dispensing of several membranes at the same time

The design allows quick and easy cleaning

Low weight for easy transport

Option to power and battery connection

Order Information

Order Number	Description	Quantity/Box
MD001	Membrane dispenser with power supply	1
MD002	Membrane dispenser with integrated battery and power supply	1
MNW020047R-SG	Cellulose nitrate white membrane. Black grid. Pore size 0.2 µm Diameter 47 mm	300
MNW045047R-SG	Cellulose nitrate white membrane. Black grid. Pore size 0.45 µm Diameter 47 mm	300
MNW045047F-SG	Cellulose nitrate white membrane. Black grid. Pore size 0.45 µm Diameter 47 mm	450
MNW045047Y-SG	Cellulose nitrate white membrane. Black grid. Pore size 0.45 µm Diameter 47 mm	1000
MNW080047R-SG	Cellulose nitrate white membrane. Black grid. Pore size 0.80 µm Diameter 47 mm	300
MNB020047R-SW	Black cellulose nitrate membrane. White grid. Pore size 0.20 µm Diameter 47 mm	300
MNB045047R-SW	Black cellulose nitrate membrane. White grid. Pore size 0.45 µm Diameter 47 mm	300
MNB065047R-SW	Black cellulose nitrate membrane. White grid. Pore size 0.65 µm Diameter 47 mm	300
MNB080047R-SW	Black cellulose nitrate membrane. White grid. Pore size 0.8 µm Diameter 47 mm	300
MPE020047R-S	PES Membrane. White. Pore size 0.2 µm Diameter 47 mm	300



2.7 Sterile disposable vacuum filtration units

CHM® VacFILSeries are single-use vacuum filtration units for sterile and vacuum filtration, mainly used for filtering and storing cell culture, tissue culture media, biological fluids and other aqueous solutions. The units contain a high quality membranes (PES and Hydrophilic PVDF) and combine highest flow-rates and throughput with extremely low protein binding and extractable. The system consists of a polystyrene receiver bottle and filter funnel with different membrane filter choices. Also includes a polyethylene neck adaptor with hose connector for vacuum filtration of your valuable laboratory samples.

Features

Available in 2 different membranes: PES and Hydrophilic PVDF

Two membrane pore sizes: 0.2 µm and 0.45 µm

Three funnel volumes: 250, 500 and 1000 ml

Three receiver bottle volumes: 250, 500 and 1000 ml

Membrane diameter: 50 and 90 mm

Light weight and heavy wall construction

Non-pyrogenic

Detergent-free

Sterile, individually packed

Membranes

PES (Polyethersulfone) with low protein binding and low extractable are the best choice for sterile filtration of cell culture media, serum, additives and buffers. Substantially faster flow rates than PVDF

PVDF (Polyvinylidene fluoride). Extremely low protein-binding. For filtration of non-aggressive aqueous and mild organic solutions, or where maximizing protein recovery is important

Order Information

Order Number	Funnel Capacity	Receiver Capacity	Diameter (mm)	Pore Size (μm)	Membrane Material	Quantity/Box
VF02250PE022T-S	250 ml	250 ml	50	0.2	PES	12
VF02250PV022T-2			50		PVDF	12
VF02250PE045T-S			50		PES	12
VF02250PV045T-S	500 ml	500 ml	50	0.45	PVDF	12
VF05500PE022T-S			90		PES	12
VF05500PV022T-S			90		PVDF	12
VF05500PE045T-S			90		PES	12
VF05500PV045T-S			90		PVDF	12
VF1000PE022T-S			1000 ml		1000 ml	90
VF1000PV022T-S	90	PVDF		12		
VF1000PE045T-S	90	PES		12		
VF1000PV045T-S	90	PVDF		12		
VF1000PE045T-S	90	PES		12		



03

SPECIALITIES

3.1	Specimen collection cards	111
3.2	Weighing paper and aluminium containers	112
3.3	Antibiotic test paper	113
3.4	Lens cleaning tissue	114
3.5	Paper for cytological analysis	115
3.6	Smelling test paper	116
3.7	Germination test paper	117
3.8	Absorbent paper for the paper industry	120
3.9	Joseph paper	121
3.10	Cellulose stoppers	122
3.11	Stainless steel mesh	125
3.12	Polyester mesh filters	128
3.13	Non-woven fabric filters	132
3.14	CHM® filtration assistants	133
3.14.1	Diatomaceous soils (Kieselgur)	133
3.14.2	Cellulose fibers	133



03

SPECIALITIES

CHMLAB offers a wide range of special papers and filters, called specialities, for different kind of industries as pharma, biotechnology, R+D, and many others.

These specialities includes Specimen collection cards, antibiotic test paper, paper for cytological analysis, germination papers and other specific papers.

3.1 Specimen collection cards

The specimen collection cards from CHM® are designed for micro-volume sampling, transport and ambient storage of biological samples, including blood. These cards are made of white and pure absorbent fibers and contain no wet-strength additives or chemicals.

The paper is customized by the requirements of the healthcare professionals to standardize sample obtained from multiple sources.

All the special designs, printing, etc... are tailor-made for each customer to fulfil all necessary specifications and components for efficient sample collection.

They can be CE marked in EU as 'sample vessel' and comply with the Directive 98/79/EC, IVD Device for HIV-1 testing.

Features

Untreated filter paper. No impregnated chemicals to interfere with the analysis.

Body fluids and blood spots dry within two hours.

They can be designed and printed in different formats.

Applications

For micro-volume samples (blood and body fluids)

Protein analysis

HIV and other infectious diseases screening

Vitamin D analysis

Technical Specifications

Basis weight	180 g/m ²
Thickness	0.48 – 0.57 mm
Ash content (800°C)	≤0.1 %
pH	5.7 to 7.5
Blood spot diameter	15 – 17 mm
Blood absorption speed	5 – 30 s/100 µl
Max. Volume loaded	70 µl

Order Information

Order Number	Description	Circles	Quantity/Box
E0903-U5NH	Specimen collection card. No Perforation	5	100
E0903-E5NH	Specimen collection card. CE. No Perforation	5	100
E0903-E5PH	Specimen collection card. CE. With Perforation	5	100
E0903-RACK	Drying Rack	12 positions	1

3.2 Weighing paper and aluminium containers

E4001 grade weighing smooth paper is the best choice to weight all type of substances. **E4002** containers are designed for weighing of substances before the nitrogen determination by Kjeldahl method. **E4000 aluminium foil dishes** with crimped sides, flat bottoms are ideal to weight of all type of products in scales and dehydrators. Can also be used as evaporating dishes.

Order Information

Order Number	Description	Size/Diameter (mm)	Quantity/Box
E4001-050050Q	Weighing paper	50x50	500
E4001-075075Q	Weighing paper	75x75	500
E4001-100100Q	Weighing paper	100x100	500
E4001-150150Q	Weighing paper	150x150	500
E4001-200200Q	Weighing paper	200x200	500
E4002-581010H	Weighing boats	58x10x10	100
E4002-702315H	Weighing boats	70x23x15	100
E4000-056Q	Weighing aluminium dishes	56	500
E4000-072Q	Weighing aluminium dishes	72	500
E4000-093Q	Weighing aluminium dishes	93	500



3.3 Antibiotic test paper

Absorbent thick paper specially designed for identification of pathogens of infectious diseases by determination of the degree of resistance against antibiotics.

Features

Made from 100% cotton linters without additives to ensure that no inhibition will appear during the incubation.

Consistent thickness (290 g/m²) and absorption volume.

Order Information

Order Number	Description	Diameter (mm)	Quantity/Box
E1020-AA040M	Antibiotic test Paper	4	1000
E1020-AA060M	Antibiotic test Paper	6	1000
E1020-AA090M	Antibiotic test Paper	9	1000
E1020-AA120M	Antibiotic test Paper	12	1000
E1020-AA130M	Antibiotic test Paper	13	1000



3.4 Lens cleaning tissue

E1400 grade is a high-quality lens cleaning tissue that provides the ideal solution to avoid scratches in lenses and other optical surfaces made from glass, quartz or plastic. The tissue is lint-free paper (12 g/m²). High absorbency ensures the safe removal of surface moisture. Very fine paper made of pure manila vegetable fiber, non-abrasive.

Order Information

Order Number	Description	Size (*) (mm)	Quantity/Box
E1400-100150Q	Lens cleaning tissue	100x150	500

(*) Other sizes are available under request.



3.5 Paper for cytological analysis

E1240 Grade. This grade is made of filter board to absorb the excess liquid from the staining of the samples in the cytological analysis. For single and multiple chambers.

Technical Specifications

Basis weight (g/m²)

420

Order Information

Order Number	Dimensions (mm)	Holes	Quantity/Box
E1240-2575D	25x75	2	200
E1240-2575D-1	25x75	1	200
E1240-2864D	28x64	2	200

SPECIALITIES



3.6 Smelling test paper

E4100 grade is an absorbent paper made with high-quality linters and cellulose. It is mainly used in perfume and cosmetic laboratories; they are protected from any type of contamination, which makes them ideal to use in laboratories where a smelling test is carried out. Weight 280 g/m².

Order Information

Order Number	Description	Size (LengthxWidth)(mm)	Quantity/Box
E4100-12010H	Smelling Test Paper	120x10	100
E4100-16020H	Smelling Test Paper	160x20	100



3.7 Germination test paper

E3014, E3236 and E3645 grades are quality germination test papers, designed to provide the best and most reliable germination results. Made of pure cellulose, low ash content, high absorption capacity and free from bacteria and other toxic substances that could potentially inhibit growth, are ideal for seed germination. The paper is available in white, yellow and grey. These colours choices allow sufficient visibility to observe seed sprouts even in poor light. The pleated strips are specially manufactured for optimum, pure growth. Recommended for the reliable evaluation of seeds. All seed testing papers meet the **ISTA** (International Seeds Test Association) and **AOSA** (Association of Official Seed Analysts) requirements.

Features

Absorbent paper for different weights

Plain or creped surface for a better manipulation

High wet tensile strength

Made with 100% pure cellulose without the addition of Cl in its manufacturing process

Ash content <0.1%

pH in neutral zone of 6.0 / 7.5

Good surface smoothness to prevent platen growth on the internal structure of the paper

Wide range of weight between 73 and 390 g/m²

Wide variety of formats: sheets, circles, smooth strips, folded strips and any other format

Applications

Method between papers, towels or Vienna roll for garden seeds or certain cereals

Jacobsen system or Copenhagen tank

Germination bells with forest seeds

Neeb test for beet seeds

Used as capillary absorption strips in hoods, or tanks

Technical Specifications

Grade	Weight (g/m ²)	Thickness (mm)	Klemm Absorption (mm/10 min*)	Humidity resistance (kN/m*)	Ash Content (%)
E3014	120	0.27	100/100	0.4/0.25	<0.1
E3236	120	0.27	100/100	0.4/0.25	<0.1
E3645	120	0.27	100/100	0.4/0.25	<0.1
E3890	390	0.930	115/120	0.65/0.40	<0.1
E3873	73	0.170	75/70	0.29/0.26	<0.1
E3819	155	0.500	110/115	0.70/0.60	<0.1

* Longitudinal direction/ transversal direction.

Technical Specifications

Grade	Type	Color	Format
E3014	-	white	pleated paper (50 double pleats)
E3236	-	yellow	pleated paper (50 double pleats)
E3645	-	grey	pleated paper (50 double pleats)
E3890	Thick	white	circles and sheets
E3819	Crêped	white	circles and sheets
E3873	Thin	white	circles and sheets

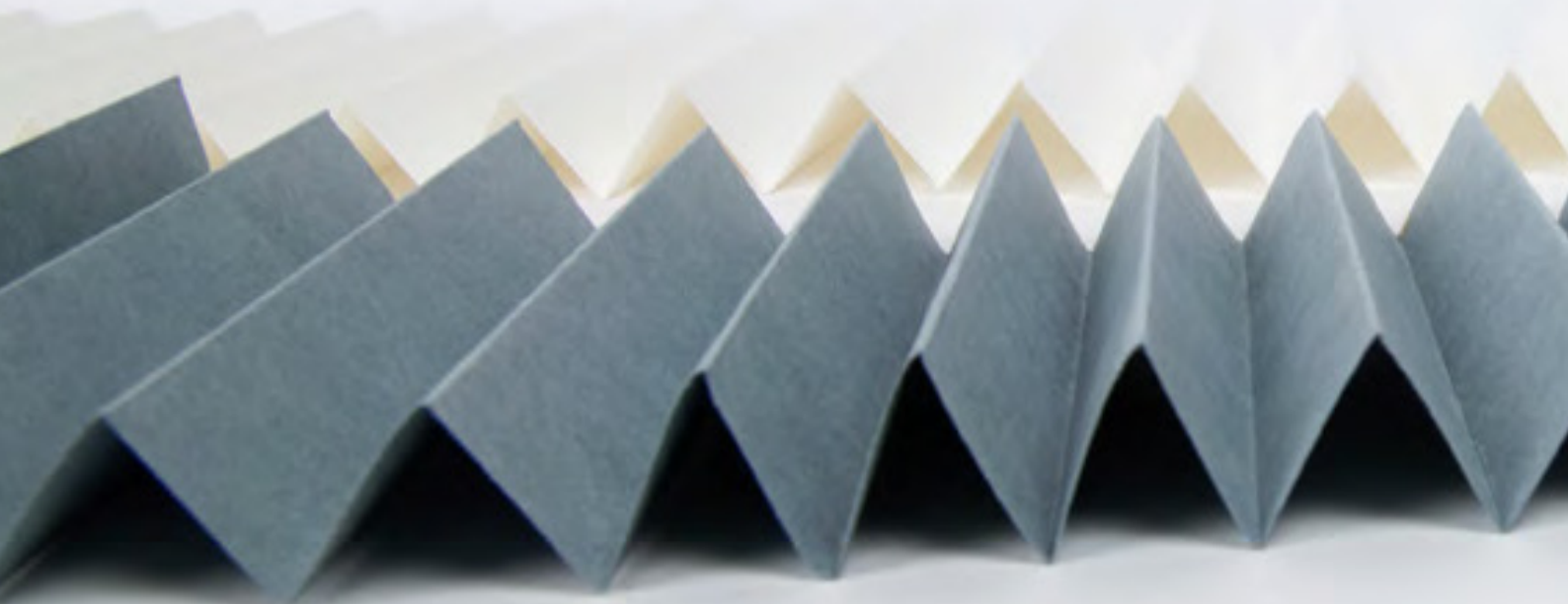

Order Information Double Pleats

	E3014 White	E3236 Yellow	E3645 Gray
Dimensions (length x wide x high) (mm)	50 Double folded sheets (100/box)		
2000x110x20	E3014-2000110H	E3236-2000110H	E3645-2000110H
	50 Double folded sheets (1000/box)		
2000x110x20	E3014-2000110M	E3236-2000110M	E3645-2000110M

Order Information Circles and Sheets

Diameter (mm)	E3890 390 gr/m ² Fine	E3819 155 gr/m ² Crêped	E3873 73 gr/m ² Fine
100 Circles/Box			
75	E3890-075	E3819-075	E3873-075
85	E3890-085	E3819-085	E3873-085
88	E3890-088	E3819-088	E3873-088
90	E3890-090	E3819-090	E3873-090
130	E3890-130	E3819-130	E3873-130
160	E3890-160	E3819-160	E3873-160
170	E3890-170	E3819-170	E3873-170
500 Sheets/Pack			
Size (mm)	E3890	E3819	E3873
110x600	-	-	E873-110600Q
320x420	E3890-320420Q	E3819-320420Q	E3873-320420Q
420x520	E3890-420520Q	E3819-420520Q	E3873-420520Q



3.8 Absorbent paper for the paper industry

An absorbent technical paper manufactured exclusively for quality controls in the cellulose paste and paper industry.

Features

The paper exactly meets the required area absorption and Klemm absorption parameters

Excellent tensile strength in wet condition

Applications

Determination of the water absorption capacity in the manufacture of glued paper in the Cobb test according to the ISO/R 535 and UNE 57-027

Sheet formation test in the cellulose paste industry according to iso 5296/1

Technical Specifications

Order Number	Weight (g/m ²)	Thickness (mm)	Area absorption AFN 20535 (g/m ²)	Klemm Absorption (mm/10 min*)	Ash content (%)
E1260	260	0.410	450 +/- 50	80/75	<0.1

(*) Longitudinal direction/ transversal direction

Order Information. Sheets

Order Number	Description	Dimensions (mm)	Quantity/Pack
E1260-100100Q	Cobb Paper	100x100	500
E1260-130130Q	Cobb Paper	130x130	500
E1260-150150Q	Cobb Paper	150x150	500
E1260-200200Q	Cobb Paper	200x200	500
E1260-230230Q	Cobb Paper	230x230	500
E1260-250250Q	Cobb Paper	250x250	500
E1260-480480H	Cobb Paper	480x480	100
E1260-420520H	Cobb Paper	420x520	100

Order Information. Circles

Order Number	Description	Dimensions (mm)	Quantity/Pack
E1260-100Q	Cobb Paper	100	500
E1260-130Q	Cobb Paper	130	500
E1260-150Q	Cobb Paper	150	500
E1260-160Q	Cobb Paper	160	500
E1260-170Q	Cobb Paper	170	500
E1260-200Q	Cobb Paper	200	500

3.9 Joseph paper

It is a thin and soft paper, commonly used for cleaning, drying and protected storage of all laboratory glassware: flasks, tubes, Erlenmeyer, beakers, special pieces, etc.

Features

Economic paper

Recyclable and compostable

Applications

Cleaning of glass elements in laboratories

Fast dry

Secure storage for glass elements

Technical Specifications

Order Number	Weight (g/m ²)	Thickness (mm)	Area absorption (g/m ²)	Klemm Absorption (mm/10 min*)
E1310	25	0.07	170	50/60

Order Information

Order Number	Description	Dimensions (mm)	Quantity/Box
E1310-350500Q	Joseph Paper	350x500	500 Sheets

3.10 Cellulose stoppers

CHM® Biostoppers have been proved as an excellent sealing for microbiological samples and tissue cultures in test tubes and Erlenmeyer flasks.

They fit perfectly into the mouth of the container.

Features

Sterilization up to 200 °C

Air permeable

Disposable



Order Information

Order Number	Description	Glass Internal Ø (mm)	Quantity/Box
CHM® Biostopper. Cellulose Stopper			
E1011-0400	Biostopper No.4	6.5-7	5000
E1011-0502	Biostopper No.5s	5.5-6.5	5000
E1011-0503	Biostopper No.5sk	4.5-6.5	5000
E1011-0604	Biostopper No.6F	6.5-7.5	5000
E1011-0700	Biostopper No.7	8.5-9.5	2000
E1011-0715	Biostopper No.7d	7.5-8.5	4000
E1011-0800	Biostopper No.8	9.5	2000
E1011-0801	Biostopper No.8P	7.5-10.5	1800
E1011-0900	Biostopper No.9	10.5-11.5	2000
E1011-0901	Biostopper No.9P	9-10.5	2000
E1011-0905	Biostopper No.9k	8.5-10.2	2000
E1011-0906	Biostopper No.9D	7-9.5	2000
E1011-1000	Biostopper No.10	9.5-11.5	1000
E1011-1100	Biostopper No.11	12-14.5	1000
E1011-1200	Biostopper No.12	11.5-13.5	1000
E1011-1201	Biostopper No.12P	11.5-13	1000
E1011-1250	Biostopper No.12,5	10.5-12.5	1000
E1011-1300	Biostopper No.13	12.5-14.5	1000
E1011-1307	Biostopper No.13H	12.5-13.5	1000
E1011-1350	Biostopper No.13,5 P	13.5-14.5	1000
E1011-1400	Biostopper No.14	13-14.5	1000
E1011-1401	Biostopper No.14P	12-14	1000
E1011-1406	Biostopper No.14D	11.5-13	1000
E1011-1409	Biostopper No.14LF	14-16	4000
E1011-1410	Biostopper No.14LD	12-14.5	4000
E1011-1424	Biostopper No.14L.v.u.	13-14.5	1000
E1011-1450	Biostopper No.14,5	14-16	1000
E1011-1500	Biostopper No.15	13.5-15.5	500
E1011-1501	Biostopper No.15P	14-16.5	5000
E1011-1513	Biostopper No.15PB	14.5-15.5	4000
E1011-1514	Biostopper No.15PI	14.7-15.5	4000
E1011-1515	Biostopper No.15 thick	13.5-16.0	5000
E1011-1516	Biostopper No.15E	15.5-17	5000
E1011-1517	Biostopper No.15 DD	14-16.5	5000
E1011-1518	Biostopper 15 l.v.u.	13.5-15.5	1000
E1011-1600	Biostopper No.16	16.5-18	5000
E1011-1700	Biostopper No.17	13-16	1000
E1011-1800	Biostopper No.18	17.5-18.5	500

Order Information

Order Number	Description	Glass Internal Ø (mm)	Quantity/Box
CHM® Biostopper. Cellulose Stopper			
E1011-1801	Biostopper No.18P	17.5-19.5	500
E1011-1806	Biostopper No.18D	17.5-19.5	500
E1011-1808	Biostopper No.18 long	17-19	3000
E1011-1900	Biostopper No.19	19-22	2500
E1011-2000	Biostopper No.20	20.5-22	400
E1011-2001	Biostopper No.20P	19-22.5	2500
E1011-2018	Biostopper No.20M	18.5-19.5	500
E1011-2019	Biostopper No.20A	20.5-22.5	500
E1011-2150	Biostopper No.21,5	17.5-21.5	3000
E1011-2205	Biostopper No.22 short	21.5-23	500
E1011-2208	Biostopper No.22long	22-24	2000
E1011-2350	Biostopper No.23,5P	25-27	2000
E1011-2600	Biostopper No.26	26-27	2000
E1011-2700	Biostopper No.27	27-32.5	1000
E1011-2705	Sealable Biostopper for drosophila culture tube	27-32.5	2500
E1011-2721	Biostopper Magnum	26-30	800
E1011-2723	Biostopper No.MA2/3	25.5-29	250
E1011-2900	Biostopper No.29	29.5-31	850
E1011-2905	Biostopper No.29k	26-27	2500
E1011-2919	Biostopper No.29A	29-30	1500
E1011-3200	Biostopper No.32	32.5-35	800
E1011-3201	Biostopper No.32P	32-33	750
E1011-3225	Biostopper No.32PD	30-32.5	750
E1011-3400	Biostopper No.34	33.5-36.5	750
E1011-3600	Biostopper No.36	35.5-39.5	600
E1011-3700	Biostopper No.37	37.5-41.5	600
E1011-3800	Biostopper No.38	40-43.5	500
E1011-4001	Biostopper No.40P	42-46.5	500
E1011-4501	Biostopper No.45P	47-48	300
E1011-4504	Biostopper No.45P DL	47-48	300
E1011-4800	Biostopper Nr.48	47-49	400
E1011-5003	Biostopper Nr. 50 Z, length: 8 cm , 5 cm diameter	47-49	200
E1011-6001	Biostopper No.60P	57-60	200
E1011-7005	Biostopper Nr.70k	69-71	100

3.11 Stainless steel mesh

A stainless steel mesh filter is a surface filter made of wire strands intertwined in an orderly manner and with adequate tension.

The production of this filter must comply with the criteria of the ISO 9044 standard, both concerning its characteristics and tolerances, but also to the raw material: stainless steel wire.

The parameters of these filters are different from those of a depth filter such as filter paper. These filters have a liquid passage (pore) called a mesh size that is between 10 and 1000 μm and has a perfectly squared shape.

The most important parameters are:

Mesh size (w): It is the length of the bisector of the square of the mesh size expressed in μm .

Wire diameter (d): Wire diameter before weaving, expressed in μm

Useful sieving surface (Fo): It is the ratio between the area of the openings for the total surface of the mesh. $Fo = (w/p)^2 \times 100$, expressed in %.

Weight (G): It is the weight in kg/m^2 of the metal mesh $G = 12.61 \times (d^2/p)$

Stainless steel quality: Following AISI 304 or AISI 316 standards.

Features

High precision of the structure and the mesh size
Excellent chemical compatibility against all types of solvents
High tensile strength
Suitable for exposure to extremely high temperatures
Very wide mesh size range (between 10 and 1000 μm)
Diameters from 47 to 150 mm

Applications

Support for depth filters in filtration or separation systems
Pre-filtration of samples with large particles
Separation of samples of cosmetic products
Filtration of samples of aggressive solvents with solid particles
Separation of solid samples by gauges
Retention of particles in cascade through mechanical vibration systems
Safety protection in industrial production lines
Filtration of samples which require bigger pore size



Order Information

Order Number	Description	Diameter (mm)	Quantity/Box
E52010-047	INOX mesh 10 µm	47	100
E52010-050	INOX mesh 10 µm	50	100
E52010-055	INOX mesh 10 µm	55	100
E52010-070	INOX mesh 10 µm	70	100
E52010-090	INOX mesh 10 µm	90	100
E52010-110	INOX mesh 10 µm	110	100
E52010-125	INOX mesh 10 µm	125	100
E52010-150	INOX mesh 10 µm	150	100
E52025-047	INOX mesh 25 µm	47	100
E52025-050	INOX mesh 25 µm	50	100
E52025-055	INOX mesh 25 µm	55	100
E52025-070	INOX mesh 25 µm	70	100
E52025-090	INOX mesh 25 µm	90	100
E52025-110	INOX mesh 25 µm	110	100
E52025-125	INOX mesh 25 µm	125	100
E52025-150	INOX mesh 25 µm	150	100
E52050-047	INOX mesh 50 µm	47	100
E52050-050	INOX mesh 50 µm	50	100
E52050-055	INOX mesh 50 µm	55	100
E52050-070	INOX mesh 50 µm	70	100
E52050-090	INOX mesh 50 µm	90	100
E52050-110	INOX mesh 50 µm	110	100
E52050-125	INOX mesh 50 µm	125	100
E52050-150	INOX mesh 50 µm	150	100
E52100-047	INOX mesh 100 µm	47	100
E52100-050	INOX mesh 100 µm	50	100
E52100-055	INOX mesh 100 µm	55	100
E52100-070	INOX mesh 100 µm	70	100
E52100-090	INOX mesh 100 µm	90	100
E52100-110	INOX mesh 100 µm	110	100
E52100-125	INOX mesh 100 µm	125	100
E52100-150	INOX mesh 100 µm	150	100
E52150-047	INOX mesh 150 µm	47	100
E52150-050	INOX mesh 150 µm	50	100
E52150-055	INOX mesh 150 µm	55	100
E52150-070	INOX mesh 150 µm	70	100
E52150-090	INOX mesh 150 µm	90	100
E52150-110	INOX mesh 150 µm	110	100
E52150-125	INOX mesh 150 µm	125	100
E52150-150	INOX mesh 150 µm	150	100

Order Number	Description	Diameter (mm)	Quantity/Box
E52200-047	INOX mesh 200 µm	47	100
E52200-050	INOX mesh 200 µm	50	100
E52200-055	INOX mesh 200 µm	55	100
E52200-070	INOX mesh 200 µm	70	100
E52200-090	INOX mesh 200 µm	90	100
E52200-110	INOX mesh 200 µm	110	100
E52200-125	INOX mesh 200 µm	125	100
E52200-150	INOX mesh 200 µm	150	100
E52250-047	INOX mesh 250 µm	47	100
E52250-050	INOX mesh 250 µm	50	100
E52250-055	INOX mesh 250 µm	55	100
E52250-070	INOX mesh 250 µm	70	100
E52250-090	INOX mesh 250 µm	90	100
E52250-110	INOX mesh 250 µm	110	100
E52250-125	INOX mesh 250 µm	125	100
E52250-150	INOX mesh 250 µm	150	100
E52500-047	INOX mesh 500 µm	47	100
E52500-050	INOX mesh 500 µm	50	100
E52500-055	INOX mesh 500 µm	55	100
E52500-070	INOX mesh 500 µm	70	100
E52500-090	INOX mesh 500 µm	90	100
E52500-110	INOX mesh 500 µm	110	100
E52500-125	INOX mesh 500 µm	125	100
E52500-150	INOX mesh 500 µm	150	100
E5201M-047	INOX mesh 1000 µm	47	100
E5201M-050	INOX mesh 1000 µm	50	100
E5201M-055	INOX mesh 1000 µm	55	100
E5201M-070	INOX mesh 1000 µm	70	100
E5201M-090	INOX mesh 1000 µm	90	100
E5201M-110	INOX mesh 1000 µm	110	100
E5201M-125	INOX mesh 1000 µm	125	100
E5201M-150	INOX mesh 1000 µm	150	100

3.12 Polyester mesh filters

Polyester mesh filters ($C_{10}H_8O_4$) have the same structure as stainless steel mesh filters. Only the raw material changes, which for this range of products is polyester, a polymer with excellent resistance to traction, at high temperatures (melting point at $256^{\circ}C$) and high chemical compatibility against a large part of solvents.

The parameters that identify a polyester mesh are:

Mesh size (w): It is the length of the bisector of the square of the mesh size expressed in μm .

Wire diameter (d): Wire diameter before weaving, expressed in mm

Useful sieving surface (Fo): It is the ratio between the area of the openings for the total surface of the mesh. $Fo = (w/p)^2 \times 100$, expressed in %.

The range is made up of filters with mesh size from 5 to 1,000 μm .

Features

- High precision of the structure and the mesh size
- Good chemical compatibility
- Excellent tensile strength
- High resistance to temperature
- Very wide mesh size range (between 5 and 1000 μm)

Applications

- Retention of solid particles in water
- Analysis of coal dust particles
- Soil analysis
- Pre-filtration of samples before a depth filter
- Collection of marine algae and microorganisms
- Filtration of paint samples
- Determination of particle size in abrasion polishing processes of metal parts
- Security Filtration in production lines
- Studies of the presence, size and shape of microplastics in marine and continental waters



Order Information

Order Number	Description	Diameter (mm)	Quantity/Box
E51005-047	Polyester mesh 5 µm	47	50
E51005-050	Polyester mesh 5 µm	50	50
E51005-055	Polyester mesh 5 µm	55	50
E51005-070	Polyester mesh 5 µm	70	50
E51005-090	Polyester mesh 5 µm	90	50
E51005-110	Polyester mesh 5 µm	110	50
E51005-125	Polyester mesh 5 µm	125	50
E51005-150	Polyester mesh 5 µm	150	50
E51010-047	Polyester mesh 10 µm	47	50
E51010-050	Polyester mesh 10 µm	50	50
E51010-055	Polyester mesh 10 µm	55	50
E51010-070	Polyester mesh 10 µm	70	50
E51010-090	Polyester mesh 10 µm	90	50
E51010-110	Polyester mesh 10 µm	110	50
E51010-125	Polyester mesh 10 µm	125	50
E51010-150	Polyester mesh 10 µm	150	50
E51025-047	Polyester mesh 25 µm	47	50
E51025-050	Polyester mesh 25 µm	50	50
E51025-055	Polyester mesh 25 µm	55	50
E51025-070	Polyester mesh 25 µm	70	50
E51025-090	Polyester mesh 25 µm	90	50
E51025-110	Polyester mesh 25 µm	110	50
E51025-125	Polyester mesh 25 µm	125	50
E51025-150	Polyester mesh 25 µm	150	50
E51035-047	Polyester mesh 35 µm	47	50
E51035-050	Polyester mesh 35 µm	50	50
E51035-055	Polyester mesh 35 µm	55	50
E51035-070	Polyester mesh 35 µm	70	50
E51035-090	Polyester mesh 35 µm	90	50
E51035-110	Polyester mesh 35 µm	110	50
E51035-125	Polyester mesh 35 µm	125	50
E51035-150	Polyester mesh 35 µm	150	50
E51050-047	Polyester mesh 50 µm	47	50
E51050-050	Polyester mesh 50 µm	50	50
E51050-055	Polyester mesh 50 µm	55	50
E51050-070	Polyester mesh 50 µm	70	50
E51050-090	Polyester mesh 50 µm	90	50
E51050-110	Polyester mesh 50 µm	110	50
E51050-125	Polyester mesh 50 µm	125	50
E51050-150	Polyester mesh 50 µm	150	50

Order Number	Description	Diameter (mm)	Quantity/Box
E51080-047	Polyester mesh 80 µm	47	50
E51080-050	Polyester mesh 80 µm	50	50
E51080-055	Polyester mesh 80 µm	55	50
E51080-070	Polyester mesh 80 µm	70	50
E51080-090	Polyester mesh 80 µm	90	50
E51080-110	Polyester mesh 80 µm	110	50
E51080-125	Polyester mesh 80 µm	125	50
E51080-150	Polyester mesh 80 µm	150	50
E51105-047	Polyester mesh 105 µm	47	50
E51105-050	Polyester mesh 105 µm	50	50
E51105-055	Polyester mesh 105 µm	55	50
E51105-070	Polyester mesh 105 µm	70	50
E51105-090	Polyester mesh 105 µm	90	50
E51105-110	Polyester mesh 105 µm	110	50
E51105-125	Polyester mesh 105 µm	125	50
E51105-150	Polyester mesh 105 µm	150	50
E51150-047	Polyester mesh 150 µm	47	50
E51150-050	Polyester mesh 150 µm	50	50
E51150-055	Polyester mesh 150 µm	55	50
E51150-070	Polyester mesh 150 µm	70	50
E51150-090	Polyester mesh 150 µm	90	50
E51150-110	Polyester mesh 150 µm	110	50
E51150-125	Polyester mesh 150 µm	125	50
E51150-150	Polyester mesh 150 µm	150	50
E51200-047	Polyester mesh 200 µm	47	50
E51200-050	Polyester mesh 200 µm	50	50
E51200-055	Polyester mesh 200 µm	55	50
E51200-070	Polyester mesh 200 µm	70	50
E51200-090	Polyester mesh 200 µm	90	50
E51200-110	Polyester mesh 200 µm	110	50
E51200-125	Polyester mesh 200 µm	125	50
E51200-150	Polyester mesh 200 µm	150	50
E51250-047	Polyester mesh 250 µm	47	50
E51250-050	Polyester mesh 250 µm	50	50
E51250-055	Polyester mesh 250 µm	55	50
E51250-070	Polyester mesh 250 µm	70	50
E51250-090	Polyester mesh 250 µm	90	50
E51250-110	Polyester mesh 250 µm	110	50
E51250-125	Polyester mesh 250 µm	125	50
E51250-150	Polyester mesh 250 µm	150	50
E51500-047	Polyester mesh 500 µm	47	50

Order Number	Description	Diameter (mm)	Quantity/Box
E51500-050	Polyester mesh 500 µm	50	50
E51500-055	Polyester mesh 500 µm	55	50
E51500-070	Polyester mesh 500 µm	70	50
E51500-090	Polyester mesh 500 µm	90	50
E51500-110	Polyester mesh 500 µm	110	50
E51500-125	Polyester mesh 500 µm	125	50
E51500-150	Polyester mesh 500 µm	150	50
E5101M-047	Polyester mesh 1000 µm	47	50
E5101M-050	Polyester mesh 1000 µm	50	50
E5101M-055	Polyester mesh 1000 µm	55	50
E5101M-070	Polyester mesh 1000 µm	70	50
E5101M-090	Polyester mesh 1000 µm	90	50
E5101M-110	Polyester mesh 1000 µm	110	50
E5101M-125	Polyester mesh 1000 µm	125	50
E5101M-150	Polyester mesh 1000 µm	150	50

3.13 Non-woven fabric filters

Non-woven fabric filters are a group of filters with special features: they are manufactured with synthetic fibers of great length by means of a dry production system and with synthetic binders. These are filters with high resistance and a very high flow rate, so they are especially suitable for very viscous samples, slurries or dense liquids.

Features

- Very high tensile strength in wet condition
- High throughput of dense liquids
- Excellent loading capacity, especially in heavy grades
- Very large pore sizes: in the order of 50 to 300 μm

Applications

- Very fast filtration of samples with large volume
- Prefiltration before the filter papers
- Recovery of large particles of precious metals
- Artificial insemination techniques in pig farming
- Collection of biological material in fish farms
- Filtration of slurries and very dense samples in quality controls of the sugar industry
- Determination of water retention in gypsum production according to the UNE/EN 102.031 standard
- Determination of the presence of impurities in raw milk and dairy products according to the GB-5413.30-2010 standard

Technical Specifications and order information

Order Number	Weight (g/m ²)	Thickness (mm)	Dry resistance (N/ 5cm)	Humid Resistance (N/ 5cm)	Air Permeability L/m ² x s (pressure: 200 Pa)
E6025	25	0.190	$\geq 50/\geq 6$	$\geq 20/\geq 3$	5200
E6035	35	0.270	$\geq 70/\geq 10$	$\geq 28/\geq 5$	4600
E6060	60	0.400	$\geq 110/\geq 22$	$\geq 40/\geq 8$	3100
E6125	125	0.850	$\geq 125/\geq 30$	$\geq 40/\geq 8$	2800

Order Information

Diameter (mm)	E6025	E6035	E6060	E6125
32	-	-	-	E6125-032
47	E6025-047	E6035-047	E6060-047	E6125-047
50	E6025-050	E6035-050	E6060-050	E6125-050
55	E6025-055	E6035-055	E6060-055	E6125-055
70	E6025-070	E6035-070	E6060-070	E6125-070
90	E6025-090	E6035-090	E6060-090	E6125-090
110	E6025-110	E6035-110	E6060-110	E6125-110
125	E6025-125	E6035-125	E6060-125	E6125-125
150	E6025-150	E6035-150	E6060-150	E6125-150
200	E6025-200	E6035-200	E6060-200	E6125-200
250	E6025-250	E6035-250	E6060-250	E6125-250

3.14 CHM® filtration assistants

3.14.1 Diatomaceous soils (Kieselgur)

They are formed by the accumulation of silicon shells of fossil algae. They are used as filtration auxiliaries in polishing processes in the manufacture of edible cherries, wines, alcohols, pharmaceuticals, etc. due to their excellent protein adsorption properties, combined with excellent liquid permeability.

In the filtration of laboratory samples, we find its usefulness in combination with a filter paper with a smaller size of fear than the measurement of the size of kieselguhr particles. This filtration aid is especially interesting in the filtration of complex samples with colloidal and deformable particle size.

Technical Specifications and Order Information

Grade	Retention Range (μm)	Land Size (μm)	Permeability (Darcy)	Filtration Speed	Quantity/Box
E11412U	1.2	66	6.5	Fast	1 kg
E11407U	0.7	24	0.8	Medium	1 kg
E11401U	0.1	13	0.07	Slow	1 kg

3.14.2 Cellulose fibers

Cellulose fibers formed by high purity cotton linters. The sample to be filtered can be mixed with the cellulose fibers, forming a suspension that favors the flocculating effect. It can also be used to form a pre-filtration bed in the funnel.

Of course, it must be used in combination with a slow speed filter paper. Depending on the ash content of cellulose fibers, these can be quantitative (<0.01%) or qualitative (0.1%)

Technical Specifications and Order Information

Grade	Quality	Ash Content (%)	Quantity/Box
E1101U	Quantitative	< 0.01	1 kg
E2101U	Qualitative	< 0.1	1 kg

Equivalence Table

CHMLAB	S&S	M&N
E1101U	121	MN101
E2101U	122/292	MN2101

04

CHROMATOGRAPHY

4.1	HPLC Columns	137
4.2	TLC Thin layer chromatography	141
4.2.1	TLC plates and sheets	141
4.2.2	Chromatography papers	142
4.3	Vials, caps and septa	144
4.3.1	CHM® 2 ml vials	146
4.3.2	Pre-assembled caps and septa for 2 ml vials	147
4.3.3	CHM® 4 ml vials, caps and septa	147
4.3.4	CHM® 10, 20 and 40 ml vials, caps and septa	148
4.4	Micro insert	149
4.5	Syringeless @Minivial	150
4.6	SPE Columns	151
4.7	QuEChERS	159



04

CHROMATOGRAPHY

Chromatography is an analytical technique used for the separation of a mixture into its individual components.

The mixture is dissolved in a fluid called the *mobile phase*, which carries it through a structure holding another material called the *stationary phase*.

The different components of the mixture travel at different speeds, causing them to separate from one another.

According to the nature of the specific mobile and stationary phases, the different compounds have differential retention times on the stationary phase and thus affect the separation.

The individual components can be thoroughly analysed.

Chromatography may be preparative or analytical, and there are many types of chromatography and techniques, but all of these employ the same basic principles.

Chromatography is a popular technique used in laboratories worldwide as an analysis tool for pharmaceuticals, food and beverage, industrial, forensics, and many other industries.

CHMLAB is offering a wide range of chromatography consumables and sample preparation with the highest quality designed to ensure the best results in your lab.

4.1 HPLC Columns

High-performance liquid chromatography (HPLC) is a technique in analytical chemistry used to separate, identify and quantify each component in a mixture.

The sample mixture to be separated and tested is sent into a stream of solvent (mobile phase) to the column which contains the chromatographic packing material needed (stationary phase) to make the separation.

The mixture moves through the column at different speeds and interacts with the stationary phase. The velocity of each component in the mixture depends on its chemical nature, the nature of the column and the composition of the mobile phase. The time at which a specific component emerges from the column is termed as its retention time.

The retention time is measured under specific conditions and considered as the identifying characteristic of a given component.

There are different types of columns available with different sorbents and particle sizes. The technique has found the immense scope of applications in both academic and industrial laboratories requiring identification and quantification of mixtures of organic compounds.

Benefits of HPLC systems

Controls and automates chromatography instrumentation

Provides data management, security features, and instrument validation

Powerful and adaptable

Increases productivity by managing all the areas of analysis - from sample to instrument, and from separation to reporting results

Applications

Preconcentration of trace components

Ligand-exchange chromatography

Ion-exchange chromatography of proteins

Drugs: Antibiotics, analgesics, sedatives, etc.

Biochemistry: Amino acids, proteins, lipids, carbohydrates, etc.

Food: Sweeteners, antioxidants, essences, etc.

Chemical Industry: Dyes, surfactants, aromatics, etc.

Contaminants: Pesticides, herbicides, chlorinated, PCB's

Forensic: Drugs, Alcohol, Poisons, Blood, etc.

Medicine: Urine Analysis, Bile Acids, etc.



ULTRABASE® C8 and C18 SERIES

The new technologies applied at the end-capping has reduced the presence of free silane groups, which have negative effects (especially with alkaline compounds) into the peaks geometry, to a value below the detection level.

Also, the C18 bond density has been standardized to achieve optimal selectivity in both hydrophilic and hydrophobic compounds.

A characteristic test that defines the quality of a phase is the behaviour against the pyridine and phenol tests.

In the chromatogram, it is observed that neither pyridine nor phenol present distortions of their peaks which demonstrates the inactivity of the free silane groups in the ULTRABASE silica.

Features

Spherical particles porous

Phase high quality

"Full end-capped"

High acid resistance

Suitable for hydrophobic mixtures

Silane levels below the detection limit

Particle size 3 and 5 μm

Pore size 110 Å

Specific surface: 310 g/m^2

Carbon content: 18%

Pore volume: 0.9

Technical Specifications and Order Information

Order Number	Packing	Particle Size (μm)	Length (mm)	Internal Diameter (mm)
U-C18-3-250-46	C18	3	250	4.6
U-C18-3-200-46	C18	3	200	4.6
U-C18-3-150-46	C18	3	150	4.6
U-C18-3-125-46	C18	3	125	4.6
U-C18-3-100-46	C18	3	100	4.6
U-C18-3-050-46	C18	3	50	4.6
U-C18-5-250-46	C18	5	250	4.6
U-C18-5-200-46	C18	5	200	4.6
U-C18-5-150-46	C18	5	150	4.6
U-C18-5-125-46	C18	5	125	4.6
U-C18-5-100-46	C18	5	100	4.6
U-C18-5-050-46	C18	5	50	4.6
U-C18-5-250-40	C18	5	250	4.0
U-C18-5-200-40	C18	5	200	4.0
U-C18-5-150-40	C18	5	150	4.0
U-C18-5-125-40	C18	5	125	4.0
U-C18-5-100-40	C18	5	100	4.0
U-C18-5-050-40	C18	5	50	4.0
U-C18-5-250-30	C18	5	250	3.0
U-C18-5-200-30	C18	5	200	3.0
U-C18-5-150-30	C18	5	150	3.0
U-C18-5-125-30	C18	5	125	3.0
U-C18-5-100-30	C18	5	100	3.0
U-C18-5-050-30	C18	5	50	3.0

Technical Specifications and Order Information

Order Number	Packing	Particle Size (μm)	Length (mm)	Internal Diameter (mm)
U-C8-5-250-46	C8	5	250	4.6
U-C8-5-200-46	C8	5	200	4.6
U-C8-5-150-46	C8	5	150	4.6
U-C8-5-125-46	C8	5	125	4.6
U-C8-5-100-46	C8	5	100	4.6
U-C8-5-050-46	C8	5	50	4.6
U-C8-5-250-40	C8	5	250	4.0
U-C8-5-200-40	C8	5	200	4.0
U-C8-5-150-40	C8	5	150	4.0
U-C8-5-125-40	C8	5	125	4.0
U-C8-5-100-40	C8	5	100	4.0
U-C8-5-050-40	C8	5	50	4.0
U-C8-5-250-30	C8	5	250	3.0
U-C8-5-200-30	C8	5	200	3.0
U-C8-5-150-30	C8	5	150	3.0
U-C8-5-125-30	C8	5	125	3.0
U-C8-5-100-30	C8	5	100	3.0
U-C8-5-050-30	C8	5	50	3.0



ULTRABASE® Si SERIES

The ULTRABASE® silica belongs to the second generation of silicas for liquid chromatography. It has been developed to fulfil all requirements to be used in chromatographic analysis.

Features

Uniformly spherical particles

High chemical purity

The impurities which most affect silica are the metal ions content, due to they cause the non-desired analyte adsorption to the chromatographic support.

The ULTRABASE® silica has high chemical purity; its metal ion content of Fe, Zr, Al and Ti is <10 ppm

Optimum porosity

During the chromatography process the analyte separation depends on the contact with the silica surface particle, it is essential to the silica porosity thus this porosity is an important parameter to define the silica quality.

ULTRABASE® silica fulfil with these requirements.

High specific surface

Due to its bigger area of specific surface presents higher retention in the separation of elements thus a better resolution.

High particle size distribution uniformity

Its extremely narrow particle distribution, the pore size of 110 Å as well as the high area of specific surface allows higher peaks retention, higher load capacity and a better resolution.

3 and 5 µm used particle sizes are suitable to fulfil the chromatographic needs from analytical to high speed.

Technical Specifications and Order Information

Order Number	Packing	Particle Size (µm)	Length (mm)	Internal Diameter (mm)
U-Si-5-250-46	Si	5	250	4.6
U-Si-5-200-46	Si	5	200	4.6
U-Si-5-150-46	Si	5	150	4.6
U-Si-5-125-46	Si	5	125	4.6
U-Si-5-100-46	Si	5	100	4.6
U-Si-5-050-46	Si	5	50	4.6
U-Si-5-250-40	Si	5	250	4.0
U-Si-5-200-40	Si	5	200	4.0
U-Si-5-150-40	Si	5	150	4.0
U-Si-5-125-40	Si	5	125	4.0
U-Si-5-100-40	Si	5	100	4.0
U-Si-5-050-40	Si	5	50	4.0
U-Si-5-250-30	Si	5	250	3.0
U-Si-5-200-30	Si	5	200	3.0
U-Si-5-150-30	Si	5	150	3.0
U-Si-5-125-30	Si	5	125	3.0
U-Si-5-100-30	Si	5	100	3.0
U-Si-5-050-30	Si	5	50	3.0

4.2 TLC Thin layer chromatography

TLC (Thin Layer Chromatography) is like all chromatographic techniques, based on a multistage distribution process. This process involves a suitable adsorbent (the stationary phase), solvents or solvent mixtures (the mobile phase), and the sample molecules. For Thin Layer Chromatography, the adsorbent is coated as a thin layer onto suitable support (e.g. glass, polyester or aluminium plate), on this layer the substance mixture is separated by elution with a suitable solvent.

The most frequently used separation technique is ascending TLC in a glass chamber (standard method, linear development). Usually, it is applied as a single development. However multiple developments, with or without change of mobile phase can improve separation results.

4.2.1 TLC plates and sheets

The CHM® TLC plates have a homogeneous coating, the homogeneous thickness of the layer, high packing density, firmly adherent layers and consistent chromatographic properties.

The standard silica coating is one of the most frequently used ready-to-use layers for TLC. For these plates, CHMLAB uses silica 60 with a mean pore diameter of 60 Å, a specific surface (BET) of about 500 m²/g, a specific pore volume of 0.75 ml/g and a particle size of 5 to 17 µm.

Manganese activated and zinc silicate is used as a fluorescent indicator for short-wave UV light (254 nm). As binder highly polymeric products are used, which are stable in almost all organic solvents and resistant towards aggressive visualisation reagents. The binder systems used for our polyester pre-coated plates are also completely stable in purely aqueous eluents.

Technical Specifications and Order Information

Order Number	Description	Plate Size (mm)	Thickness of Layer (mm)	Fluorescent Indicator Uv254	Quantity/Pack
Glass Plates					
TP1020GS	Glass TLC silica 60	100x200	0.25	NO	50
TP2020GS	Glass TLC silica 60	200x200	0.25	NO	25
TP1020GSF	Glass TLC silica 60	100x200	0.25	YES	50
TP2020GSF	Glass TLC silica 60	200x200	0.25	YES	25
Polyester Sheets					
TP2020PS	Polyester TLC with silica 60	200x200	0.2	NO	25
TP4020PS	Polyester TLC with silica 60	400x200	0.2	NO	25
TP2020PSF	Polyester TLC with silica 60	200x200	0.2	YES	25
TP4020PSF	Polyester TLC with silica 60	400x200	0.2	YES	25
Aluminium Sheets					
TP1020AS	Aluminium TLC with silica 60	100x200	0.2	NO	20
TP2020AS	Aluminium TLC with silica 60	200x200	0.2	NO	25
TP1020ASF	Aluminium TLC with silica 60	100x200	0.2	YES	20
TP2020ASF	Aluminium TLC with silica 60	200x200	0.2	YES	25

4.2.2 Chromatography papers

CHMLAB offers a complete line of high-quality papers for chromatography and electrophoresis to be used in chromatography papers application techniques and gel transfer applications. CHM® chromatography papers are made from pure linters with an α -cellulose content of nearly 100% which give them purity, high quality and homogeneous structure.

GRADE C3001

The world's standard paper for chromatography.

One of the thinnest papers, with a medium aspiration speed that provides optimum resolutions. A smooth surface. Suitable for general analytical separations.

GRADE C3002

Thin paper with a slower aspiration speed than C3001, for higher resolution applications. A smooth surface. Particularly recommended for optical or radiometric scanning.

GRADE C3003

This medium thickness paper is normally recommended for general applications with medium-heavy solute loadings. Gives a compact spot. Frequently used for separation of non-organic solutions and for electrophoresis.

Features

Extremely pure composition with 100% cotton linters, without additives nor binder resins

Extremely high perfection in the formation of the structure to achieve a homogeneous migration in any area of the sheet

Thicker papers allow higher sample volumes.

The most important features in chromatography papers are their basis weight, thickness and capillary absorption. High weight and thickness of the paper allow a greater load of solutes, obtaining better resolutions in papers with low capillary absorption levels.

GRADE C3003M

Relatively thick paper with medium wet strength. A Smooth surface. Used extensively for both electrophoreses and for general chromatography. Most widely used blotting paper. After C3001, it is the most widely used chromatography paper grade.

GRADE C3017

This paper is one of the thickest of this CHM® line that converts C3017 a suitable paper for heavy loadings. Offers a very high aspiration speed and is highly absorbent. Suitable for preparative paper chromatography and electrophoresis.

GRADE C3031

This paper of a medium thickness offers an extremely high aspiration speed and it is recommended for electrophoresis of large molecules. C3031 has a soft and uniform surface.

Perfect adjustment of the capillary absorption speed, according to each degree parameter

Grade	Applications
-------	--------------

C3001	General chromatography work School practices Determination of the presence of malic acid in wines
-------	---

C3002	General chromatography with molecules bigger than C3001 Determination of components by elution
-------	---

C3003	Chromatography assays with samples with high-medium load Separation of organic compounds Work with electrophoresis Identification of additives in food Blotting techniques according to Northern, Southern and Western Dot blot, Slot blot, sequence of genetic chains
-------	---

C3003M	Generally used for chromatography work with medium load particles Electrophoresis assays even in blotting techniques
--------	---

C3017	Used in chromatography assays with big molecule samples Generally used in electrophoresis with highly loaded samples Protein identification by semi-dry transfer
-------	--

C3031	Used in cell lysis and chromatography Generally used in electrophoresis with highly loaded samples Blotting for Western technique
-------	---

Technical Specifications

Grade	Weight (g/m ²)	Capillary Rise (mm/30min)	Thickness (μm)	Aspiration Speed
C3001	90	93	190	Medium fast
C3002	125	93	240	Medium fast
C3003	180	130	450	Fast
C3003M	180	105	380	Fast
C3017	320	240	900	Very fast
C3031	280	170	550	Very fast

Order Information

Dimensions (mm)	C3001	C3002	C3003	C3003M	C3017	C3031
93x80	C3001-093080	C3002-093080	C3003-093080	C3003M-093080	C3017-093080	C3031-093080
100x70	C3001-100070	C3002-100070	C3003-100070	C3003M-100070	C3017-100070	C3031-100070
100x150	C3001-100150	C3002-100150	C3003-100150	C3003M-100150	C3017-100150	C3031-100150
120x140	C3001-120140	C3002-120140	C3003-120140	C3003M-120140	C3017-120140	C3031-120140
150x200	C3001-150200	C3002-150200	C3003-150200	C3003M-150200	C3017-150200	C3031-150200
200x200	C3001-200200	C3002-200200	C3003-200200	C3003M-200200	C3017-200200	C3031-200200
210x90	C3001-210090	C3002-210090	C3003-210090	C3003M-210090	C3017-210090	C3031-210090
460x570	C3001-460570	C3002-460570	C3003-460570	C3003M-460570	C3017-460570	C3031-460570
580x580	C3001-580580	C3002-580580	C3003-580580	C3003M-580580	C3017-580580	C3031-580580

Equivalence Table

CHMLAB	Aspiration Speed	WHATMAN	S&S	M&N	SARTORIUS
C3001	Medium fast	1Chr	2043 a	MN261	-
C3002	Medium fast	2Chr	2043 b	MN214	FN4
C3003	Fast	3 Chr	3469	MN218	FN7
C3003M	Fast	3 MM Chr	-	MN218B	F100
C3017	Very fast	17 Chr	-	-	FN30
C3031	Very fast	31 ET Chr	2668	827	-

4.3 Vials, caps and septa

CHMLAB offers a wide range of vials, caps and septa certified to assure quality for reliable analytical results, reducing costs and saving time.

The CHM® sample vials are manufactured from borosilicate glass and following the international standards type I Class A; they meet ASTM Type I Class A and USP Type I standards.

Test dimensions are computerized with camera system during the manufacturing process to test the critical dimensions.

Features

Clear or Amber borosilicate glass: High-quality Type I, 51-expansion glass

Clear borosilicate glass: High quality Type 2, 33-expansion glass

Computerized camera system for quality control during the manufacturing process to test the vial dimensions; height, diameter, bottom thickness and neck/thread

Supplied in kits, or by separate: vials, caps and septa.

Applications

Compatible with HPLC, LCMS and GC instruments

Amber vials are used for light-sensitive samples

Amber vials are ideal for sample storage in chemical and pharmaceutical industries, as well as in research laboratories.

How to choose the right vial, cap and septa

Type of septa

PTFE:

Recommended for single injection applications

Excellent chemical compatibility

It is not possible to reseal after puncturing

Not recommended for long-term sample storage

Different types of PTFE (red, white)

PTFE/Silicone

Recommended for multiple injections

Recommended for sample storage

Once punctured the septum have the silicone chemical resistance

Different types of PTFE (red, white) and silicone (red, white)

Pre-slit PTFE/Silicone

Recommended for multiple injections

The pre-cut septa are manufactured by making a slit in the silicone layer but leaving the PTFE barrier uncut

For easier needle penetration

To release the vacuum that forms when a large volume of sample is withdrawn from a vial

Type of cap vials

Screw top vials

Excellent seal

Universal. Reusable

Crimp top vials

Excellent seal

Require specific tools. Not reusable

Snap top vials

Moderate seal

Fast, No. Universal tools required

Type of vials

Clear vials with and without writing area. Compatible with all common autosamplers

Amber vials with and without writing area. Compatible with all common autosamplers

Available in different closures (8-425, 9-425, 13-425, 24-400)

Available in different volumes: 2, 4, 10, 20 and 40 ml

They are packed in a clean environment in order to avoid external contamination, and they can be selected from different cap colours and a variety of septa.

The accurate manufacturing process for vials and closures avoids common problems during the use of auto-samplers, like dislodged septa, ghost peaks, undetected improper seal, etc, obtaining benefits confidence and accurate results, and chromatographic purity tests.

How to choose the right vial, cap and septa



1. Septum: PTFE, PTFE/Silicone, Pre-slit PTFE/Silicone

2. Cap: crimp, snap, screw

3. Vial: clear, amber (with and without writing area)

4.3.1 CHM® 2 ml vials

CHM® 2 ml 8-425 neck autosampler vials, caps and septa are compatible with all common autosamplers including Agilent, Waters, Shimadzu, etc. These smaller opening vials with an 8-425 thread size screw cap are uniformly flat bottom for security with the inserts.

PTFE/Silicone septa are most popular for HPLC applications, and pre-slit septa are easier to pierce with needles.

CHM® 2 ml 9-425 Vials are uniformly flat bottom for security with inserts. It is equivalent in dimensions to 11 mm crimp top vials and 10-425 screw vials and can be used in the same autosampler. Can be used on all common autosamplers due to their geometry, including Agilent, HTA, Shimadzu, Thermo, Varian, Waters, etc.

Order Information

Order Number	Description	Units/Box
SV2-08-GTR	2ml Clear vial, 8-425 screw top	100
SV2-08-GTRL	2ml Clear vial, 8-425 screw top, graduated with writing area	100
SV2-08-GAR	2ml Amber vial, 8-425 screw top	100
SV2-08-GARL	2ml Amber vial, 8-425 screw top, graduated with writing area	100
SV2-09-GTR	2ml Clear vial, 9-425 screw top	100
SV2-09-GTRL	2ml Clear vial, 9-425 screw top, graduated with writing area	100
SV2-09-GTC	2ml Clear vial, crimp top	100
SV2-09-GTCL	2ml Clear vial, crimp top, graduated with writing area	100
SV2-09-GTS	2ml Clear vial, snap top	100
SV2-09-GTSL	2ml Clear vial, snap top, graduated with writing area	100
SV2-09-GAR	2ml Amber vial, 9-425 screw top	100
SV2-09-GARL	2ml Amber vial, 9-425 screw top, graduated with writing area	100
SV2-09-GAC	2ml Amber vial, crimp top	100
SV2-09-GACL	2ml Amber vial, crimp top, graduated with writing area	100
SV2-09-GAS	2ml Amber vial, snap top	100
SV2-09-GASL	2ml Amber vial, snap top, graduated with writing area	100



4.3.2 Pre-assembled caps and septa for 2 ml vials

PTFE/Silicone septa are most popular for HPLC applications as a cost-effective material. Caps are made of high-quality polypropylene available in black and blue colour. Our septa use only the highest quality materials to ensure proper function and can be pre-slit to easy pierce with needles.

Order Information

Order Number	Description	Units/Box
SVAR-09-RPWS	Red PTFE/white silicone septa + Blue screw cap with hole, for 2 ml 9-425 screw top vial	100
SVAR-09-WPRS	White PTFE/red silicone septa + Blue screw cap with hole, for 2 ml 9-425 screw top vial	100
SVBR-08-RPWS	Red PTFE/white silicone septa + Black screw cap with hole, for 2 ml 8-425 screw top vial	100
SVBR-08-WPRS	White PTFE/red silicone septa + Black screw cap with hole, for 2 ml 8-425 screw top vial	100
SVAR-09-BPWS-PS	Blue PTFE/white silicone septa, Pre-slit + Blue screw cap with hole, for 2 ml 9-425 screw top vial	100
SVBR-08-BPWS-PS	Pre-slit, Blue PTFE/White silicone septa + Black screw cap with hole, for 8-425 screw top vial	100
SVAC-11-RPWS	Red PTFE/white silicone septa + Aluminium cap, for 2 ml crimp top vial	100
SVAC-11-WPRS	White PTFE/red silicone septa + Aluminium cap, for 2 ml crimp top vial	100
SVAC-11-WPRS-PS	Pre-slit, White PTFE/red silicone septa + Aluminium cap, for 2 ml crimp top vial	100
SVAC-11-RPWS-PS	Pre-slit, Red PTFE/white silicone septa + Aluminium cap, for 2 ml crimp top vial	100
SV-S-11-WPRS	White PTFE/Red silicone septa + snap cap with hole, for 2 ml snap top vial	100
SV-S-11-RPWS	Red PTFE/White silicone septa + snap cap with hole, for 2 ml snap top vial	100
SV-S-11-WPRS-PS	Pre-slit, White PTFE/Red silicone septa + snap cap with hole, for 2 ml snap top vial	100
SV-S-11-RPWS-PS	Pre-slit, Red PTFE/white silicone septa + snap cap with hole, for 2 ml snap top vial	100

4.3.3 CHM® 4 ml vials, caps and septa

CHM® 4 ml vials are widely used in compound storage as well as for chromatography sample vials. 15x45 mm vials are compatible with 13-425 screw thread closures.

Order Information

Order Number	Description	Units/Box
SV4-13-GTR	4 ml Clear vial, 15x45 mm, screw top, flat bottom	100
SV4-13-GAR	4 ml Amber vial, 15x45 mm, screw top, flat bottom	100
SVBR-13-RPWS	Red PTFE/White silicone septa + Black cap with hole, for 4 ml screw top vial	100
SVBRT13-RPWS	Red PTFE/White silicone septa + Black cap without hole, for 4 ml screw top vial	100

4.3.4 CHM® 10, 20 and 40 ml vials, caps and septa

Crimp top headspace vials

Clear glass headspace vial for GC autosampler. Specially manufactured to provide uniform glass thickness which ensures uniform heat distribution for consistent sampling reliability.

Order Information

Order Number	Description	Units/Box
SV10-22-GTC	10 ml Clear vial, 22.5×46 mm, crimp top, flat bottom	100
SV20-22-GTC	20 ml Clear vial, 22.5×75 mm, crimp top, flat bottom	100
SV20R22-GTC	20 ml Clear vial, 22.5×75 mm, crimp top, round bottom	100
SV10R18-GTR	10 ml Clear vial, 22.5×46 mm screw top, round bottom	100
SV20R18-GTR	20 ml Clear vial, 22.5×75 mm screw top, round bottom	100
SVAC-22-WPWS	White PTFE/White Silicone + Aluminium cap with hole, for 10 ml/20 ml crimp top vial	100
SVAC-22-RPWS	Red PTFE/White Silicone + Aluminium cap with hole, for 10 ml/20 ml crimp top vial	100
SVAR-18-BPWS	Blue PTFE/White silicone septa + Silver screw cap with hole, for 18 mm screw top vial	100

EPA/VOA/Storage vials

CHMLAB offers many standard vials and vial kits for volatiles sampling, compound storage and other non-chromatography applications. In addition, most products can be deactivated and/or packaged for special applications (package of a biological agent, cosmetics, high-value chemistry, etc.)

Order Information

Order Number	Description	Units/Box
SV20-24-GTR	20ml Clear vial, 24-400 screw top	100
SV20-24-GAR	20ml Amber vial, 24-400 screw top	100
SV40-24-GTR	40ml Clear vial, 24-400 screw top	100
SV40-24-GAR	40ml Amber vial, 24-400 screw top	100
SVBRT24-NPNS	Nature PTFE/Nature silicone septa + Black screw cap without hole, for 24-400 screw top vial	100
SVBR-24-NPNS	Nature PTFE/Nature silicone septa + Black screw cap with hole, for 24-400 screw top vial	100

4.4 Micro insert

CHMLAB has a variety of micro inserts to limit the volume of a full-capacity sample vial in a simple step. In order to meet your microsampling needs, our micro inserts are compatible with all the CHM® screw, snap and crimp vials.

Order Information

Order Number	Description	Units/Box
SVIFB-GT	Glass insert, flat base. Recommended fill volume 400 μ L (max. 440 μ L)	100
SVICS-GT	Conical Glass insert, with polyspring. Recommended fill volume 250 μ L (max. 320 μ L)	100
SVICB-GT	Conical Glass insert. Recommended fill volume 250 μ L (max. 320 μ L)	100



4.5 Syringeless @Minivial

Our CHM® Syringeless @miniVIAL is designed to speed up the sample preparation in one step, minimizing the sample lost and reducing the time by avoiding the multistep and liquid transfers.

With this disposable vial we only need to:

- fill the sample
- insert the plunger
- press and the filtered sample is ready for analysis

This avoids the classic process of syringe + syringe filter + vial + septa&cap

CHM® @miniVIAL is compatible with the most common autosamplers, Agilent, Waters, Thermo, etc...

The @miniVIAL is available in Nylon, PTFE, Regenerated Cellulose, PVDF and PES in both pore sizes 0.2 µm and 0.45 µm.

Specifications

Dimensions: 12 mm Ø x 33 mm height

Material: Polypropylene

Septa: PTFE and silicone

Membrane material:

Nylon, Hydrophilic PTFE, Regenerated Cellulose, PVDF and PES

Capacity: 0.48 ml

Technical Specifications and Order Information

Order Number	Description	Pore Size (µm)	Color Code	Units/Box
SVNY020H	miniVIAL with Nylon membrane	0.2	Light blue	100
SVNY020M	miniVIAL with Nylon membrane	0.2	Light blue	1000
SVNY045H	miniVIAL with Nylon membrane	0.45	Blue	100
SVNY045M	miniVIAL with Nylon membrane	0.45	Blue	1000
SVTF020H	miniVIAL with Hydrophilic PTFE membrane	0.2	Pink	100
SVTF020M	miniVIAL with Hydrophilic PTFE membrane	0.2	Pink	1000
SVTF045H	miniVIAL with Hydrophilic PTFE membrane	0.45	Red	100
SVTF045M	miniVIAL with Hydrophilic PTFE membrane	0.45	Red	1000
SVRC020H	miniVIAL with Regenerated Cellulose membrane	0.2	Grey	100
SVRC020M	miniVIAL with Regenerated Cellulose membrane	0.2	Grey	1000
SVRC045H	miniVIAL with Regenerated Cellulose membrane	0.45	Black	100
SVRC045M	miniVIAL with Regenerated Cellulose membrane	0.45	Black	1000
SVPV020H	miniVIAL with PVDF membrane	0.2	Yellow	100
SVPV020M	miniVIAL with PVDF membrane	0.2	Yellow	1000
SVPV045H	miniVIAL with PVDF membrane	0.45	Orange	100
SVPV045M	miniVIAL with PVDF membrane	0.45	Orange	1000
SVPE020H	miniVIAL with PES membrane	0.2	Light green	100
SVPE020M	miniVIAL with PES membrane	0.2	Light green	1000
SVPE045H	miniVIAL with PES membrane	0.45	Green	100
SVPE045M	miniVIAL with PES membrane	0.45	Green	1000

4.6 SPE Columns

CHM® CHROMPACK SPE columns

Solid-Phase Extraction (SPE) is a separation process by which compounds that are dissolved or suspended in a liquid mixture are separated from other compounds in the mixture according to their physical and chemical properties.

Analytical laboratories use solid-phase extraction to concentrate and purify samples for analysis.

Solid-phase extraction can be used to isolate analytcs of interest from a wide variety of matrices, including urine, blood, water, beverages, soil and animal tissue.

Our manufacturing process minimizes variability and improves recovery and clean-up procedures.

Features

Available in different sizes: 1, 3, 6 and 12 ml

Quality sorbents for consistent results; from 50 mg to 1 g

Available in different packing materials

High retention rate and recovery

Very good extraction and flow characteristics

Applications

Biological samples and natural compounds

Pharmaceuticals and drugs

Pesticides and antibiotics in food and agricultural matrices

Environmental samples organic compounds and pollutants

Chrompack SPE Products

Silica Base Sorbents	Polymer Base Sorbents	Adsorption Base Sorbents	Mix Sorbents
Silica	HLB	Florisil	GCB/NH ₂
C18	MCX	GCB	GCB/PSA
C18-ne	MAX	Alumina-A	
C8		Alumina-B	
CN		Alumina-N	
NH ₂			
PSA			
SAX			
SCX			

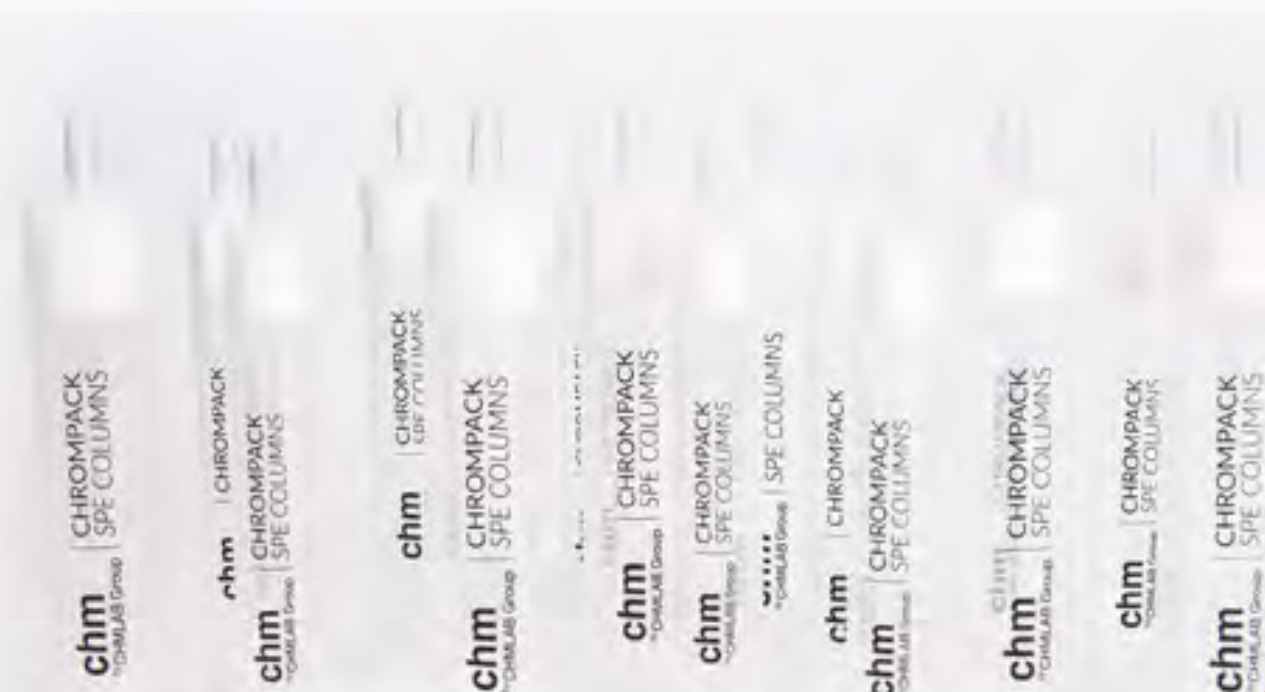

Silica Base Sorbents	Technical Specifications	Features
Silica Unbounded Silica Gel	Surface area: 480 m ² /g Particle size: 40-75 μm Pore size: 70 Å	<ul style="list-style-type: none"> * Silica is an unbounded silica gel sorbent * High sample loadabilities * Capable of separating compounds with a similar structure * Extract polar compounds
C18 Endcapped Octadecyl	Surface area: 300 m ² /g Particle size: 40-75 μm Pore size: 70 Å Carbon content: 17.6%	<ul style="list-style-type: none"> * Composed of end-capped octadecyl-bounded silica gel particles * High carbon content * Reduce interference from basic and polar compounds * Extract non-polar compounds
C18-ne Unencapped Octadecyl	Surface area: 300 m ² /g Particle size: 40-75 μm Pore size: 100 Å Carbon content: 17%	<ul style="list-style-type: none"> * Composed of end-capped octadecyl-bounded silica gel particles * High carbon content * Abundant residual silanols * General purpose sorbent * Extract polar and non-polar compounds
C8 Octyl	Surface area: 280 m ² /g Particle size: 40-75 μm Pore size: 100 Å Carbon content: 9%	<ul style="list-style-type: none"> * Composed of octyl-bounded silica gel particles * Moderate Hydrophobicity * Capable of extracting compounds which are strongly retained by C18 * Extract non-polar compounds
CN Cyanopropyl	Surface area: 480 m ² /g Particle size: 40-75 μm Pore size: 70 Å Carbon content: 5.8%	<ul style="list-style-type: none"> * CN is a cyanopropyl bounded silica sorbent * Compatible with biological matrices * Polarity adjustable by changing ratio of solvents * Extract polar and non-polar compounds, enrich metal ions
NH₂ Aminopropyl	Surface area: 480 m ² /g Particle size: 40-75 μm Pore size: 70 Å Carbon content: 4.5%	<ul style="list-style-type: none"> * Composed of aminopropyl-bounded silica gel. * Retain compounds in normal-phase or anion exchange mode * Capable of cleaning up biological samples with complicated matrix components * Extract moderately polar and acidic compounds
PSA Primary-Secondary Amine	Surface area: 480 m ² /g Particle size: 50-75 μm Pore size: 70 Å Carbon content: 8%	<ul style="list-style-type: none"> * PSA sorbent is similar to NH₂ offering both normal phase and anion exchange retention * Higher capabilities than NH₂ sorbent * Effectively removing acidic interfaces in food samples * Extract strong acids, polar compounds and metal ions
SAX Strong Anion Exchange	Surface area: 480 m ² /g Particle size: 40-75 μm Pore size: 70 Å	<ul style="list-style-type: none"> * SAX is a silica-based strong anion exchanger * Capable of retaining compounds that are not retained with weak anion exchange sorbents * Simple retention mechanism, with minimal secondary interactions * Extract acidic compounds
SCX Strong Cation Exchange	Surface area: 480 m ² /g Particle size: 40-75 μm Pore size: 70 Å	<ul style="list-style-type: none"> * SCX is a silica-based strong cation exchanger * Low pKa, enabling strong interaction with basic compounds * Electrical charge of sulfonic acid changeable by adjusting pH of eluent, ensuring convenient elution * Extract basic compounds

Polymer Base Sorbents	Technical Specifications	Features
HLB Hydrophilic-Lipophilic Balanced	Surface area: 600 m ² /g Particle size: 40 μm Pore size: 300 Å	<ul style="list-style-type: none"> * Composed of monodisperse N-vinylpyrrolidone-divinylbenzene copolymer resin particles * Specific mixture of hydrophilic and hydrophobic groups * Stable from pH 1 to 14, compatible with most common solvents * Extract non-polar to moderately polar acidic, neutral and basic compounds
MCX Mixed-mode Cation Exchange	Surface area: 600 m ² /g Particle size: 40 μm Pore size: 300 Å	<ul style="list-style-type: none"> * Composed of monodisperse polystyrene-divinylbenzene resin particles grafted with aromatic sulfonic acid groups * Superb retention for basic compounds * Stable from pH 1 to 14, compatible with most common solvents * Extract basic compounds
MAX Mixed-mode Anion Exchange	Partical size: 50 μm Pore size: 80 Å area: 600-800 m ²	<ul style="list-style-type: none"> * Composed of monodisperse polystyrene-divinylbenzene resin particles grafted with aromatic quaternary ammonium groups * Wettable, rare breakthrough * Superb retention for acidic compounds * Stable from pH 1 to 14, compatible with most common solvents * Extract acidic compounds
Adsorption Base Sorbents	Technical Specifications	Features
Florisil Pesticide Grade Florosil	Particle size: 150-250 μm	<ul style="list-style-type: none"> * Pesticide grade Florisil is a selective adsorbent comprised of synthetic magnesium-silica gel activated at 675°C. * Good retention for most pesticides * Suitable for viscous samples * Extract multiresidual pesticides
GCB Graphitized carbon Black	Surface area: 100 m ² /g Particle size: 100-300 mesh	<ul style="list-style-type: none"> * Carb-GCB is composed of sheet-like, non-porous graphitized carbon black with an aromatic six-member ring structure and positive charges. * Higher extraction speed and capability * Extract herbicides in drinking water
Alumina-A	Surface area > 150 m ² /g pH: 4.0	<ul style="list-style-type: none"> * Extremely polar sorbent * Good retention for electron-rich compounds * More stable in high pH conditions than un-bounded silica * Extract aromatic amines
Alumina-B	Surface area > 150 m ² /g pH: 9.5	<ul style="list-style-type: none"> * Extremely polar sorbent * Good retention for electron-rich compounds * More stable in high pH conditions than un-bounded silica * Extract aromatic amines
Alumina-N	Surface area > 150 m ² /g pH: 7.0	<ul style="list-style-type: none"> * Extremely polar sorbent * Good retention for electron-rich compounds * More stable in high pH conditions than un-bounded silica * Extract aromatic amines



Mix Sorbents

Technical Specifications

Features

<p>GCB/NH₂ Graphitized Carbon Black / Aminopropyl Bilayer</p>	<p>Specifications for Carb-GCB: Surface area: 100 m²/g Particle size: 100-300 mesh Specifications for NH₂: Surface area: 480 m²/g Particle size: 40-75 μm Pore size: 70 Å Carbon content: 4.5%</p>	<p>* Carb-GCB/NH₂ combines the merits of both carb-GCB and NH₂ sorbents. * Ultrathin frits between two sorbents layers promising uniform flow * Clean up of samples in multiresidual pesticide analysis</p>
<p>GCB/PSA Graphitized Carbon Black / Primary-Secondary Amine Bilayer</p>	<p>Specifications for Carb-GCB: Surface area: 100 m²/g Particle size: 100-300 mesh Specifications for PSA: Surface area: 480 m²/g Particle size: 50-75 μm Pore size: 70 Å Carbon content: 8%</p>	<p>* Carb-GCB/PSA is a sorbent similar to Carb-GCB/NH₂ and due to the additional secondary amino groups, PSA has higher ion exchange capability * Clean up of samples in multiresidual pesticide analysis</p>

Technical Specifications and Order Information (*)

Order Number	Sorbent	Mass (mg)	Volume (ml)	Quantity/Box
CPESI0050-1	Silica	50	1	100
CPESI0100-1		100	1	100
CPESI0200-3		200	3	50
CPESI0500-3		500	3	50
CPESI0500-6		500	6	30
CPESI1000-6		1000	6	30
CPESI1000-12		1000	12	20
CPESI2000-12		2000	12	20
CPEC180050-1	C18	50	1	100
CPEC180100-1		100	1	100
CPEC180200-3		200	3	50
CPEC180500-3		500	3	50
CPEC180500-6		500	6	30
CPEC181000-6		1000	6	30
CPEC181000-12		1000	12	20
CPEC182000-12		2000	12	20
CPEC18N0050-1	C18-ne	50	1	100
CPEC18N0100-1		100	1	100
CPEC18N0200-3		200	3	50
CPEC18N0500-3		500	3	50
CPEC18N0500-6		500	6	30
CPEC18N1000-6		1000	6	30
CPEC18N1000-12		1000	12	20
CPEC18N2000-12		2000	12	20

Order Number	Sorbent	Mass (mg)	Volume (ml)	Quantity/Box
CPEC80050-1	C8	50	1	100
CPEC80100-1		100	1	100
CPEC80200-3		200	3	50
CPEC80500-3		500	3	50
CPEC80500-6		500	6	30
CPEC81000-6		1000	6	30
CPEC81000-12		1000	12	20
CPEC82000-12		2000	12	20
CPECN0050-1	CN	50	1	100
CPECN0100-1		100	1	100
CPECN0200-3		200	3	50
CPECN0500-3		500	3	50
CPECN0500-6		500	6	30
CPECN1000-6		1000	6	30
CPECN1000-12		1000	12	20
CPECN2000-12		2000	12	20
CPENH20050-1	NH ₂	50	1	100
CPENH20100-1		100	1	100
CPENH20200-3		200	3	50
CPENH20500-3		500	3	50
CPENH20500-6		500	6	30
CPENH21000-6		1000	6	30
CPENH21000-12		1000	12	20
CPENH22000-12		2000	12	20
CPEPSA0050-1	PSA	50	1	100
CPEPSA0100-1		100	1	100
CPEPSA0200-3		200	3	50
CPEPSA0500-3		500	3	50
CPEPSA0500-6		500	6	30
CPEPSA1000-6		1000	6	30
CPEPSA1000-12		1000	12	20
CPEPSA2000-12		2000	12	20
CPESAX0050-1	SAX	50	1	100
CPESAX0100-1		100	1	100
CPESAX0200-3		200	3	50
CPESAX0500-3		500	3	50
CPESAX0500-6		500	6	30
CPESAX1000-6		1000	6	30
CPESAX1000-12		1000	12	20
CPESAX2000-12		2000	12	20

Order Number	Sorbent	Mass (mg)	Volume (ml)	Quantity/Box	
CPESCX0050-1	SCX	50	1	100	
CPESCX0100-1		100	1	100	
CPESCX0200-3		200	3	50	
CPESCX0500-3		500	3	50	
CPESCX0500-6		500	6	30	
CPESCX1000-6		1000	6	30	
CPESCX1000-12		1000	12	20	
CPESCX2000-12		2000	12	20	
CPEHLB0030-1		HLB	30	1	100
CPEHLB0060-1	60		1	100	
CPEHLB0100-1	100		1	100	
CPEHLB0030-3	30		3	50	
CPEHLB0060-3	60		3	50	
CPEHLB0150-3	150		3	50	
CPEHLB0200-3	200		3	50	
CPEHLB0150-6	150		6	30	
CPEHLB0200-6	200		6	30	
CPEHLB0500-6	500		6	30	
CPEHLB0500-12	500		12	20	
CPEHLB1000-12	1000		12	20	
CPEMCX0030-1	MCX	30	1	100	
CPEMCX0060-1		60	1	100	
CPEMCX0100-1		100	1	100	
CPEMCX0030-3		30	3	50	
CPEMCX0060-3		60	3	50	
CPEMCX0200-3		200	3	50	
CPEMCX0150-6		150	6	30	
CPEMCX0200-6		200	6	30	
CPEMCX0500-6		500	6	30	
CPEMCX0500-12		500	12	20	
CPEMAX0030-1		MAX	30	1	100
CPEMAX0060-1			60	1	100
CPEMAX0100-1	100		1	100	
CPEMAX0030-3	30		3	50	
CPEMAX0060-3	60		3	50	
CPEMAX0200-3	200		3	50	
CPEMAX0150-6	150		6	30	
CPEMAX0200-6	200		6	30	
CPEMAX0500-6	500		6	30	
CPEMAX0500-12	500		12	20	

Order Number	Sorbent	Mass (mg)	Volume (ml)	Quantity/Box	
CPEFL0050-1	Florisil	50	1	100	
CPEFL0100-1		100	1	100	
CPEFL0200-3		200	3	50	
CPEFL0500-3		500	3	50	
CPEFL0500-6		500	6	30	
CPEFL1000-6		1000	6	30	
CPEFL1000-12		1000	12	20	
CPEFL2000-12		2000	12	20	
CPEGCB0050-1		GCB	50	1	100
CPEGCB0100-1			100	1	100
CPEGCB0200-3			200	3	50
CPEGCB0250-3			250	3	50
CPEGCB0500-3	500		3	50	
CPEGCB0500-6	500		6	30	
CPEGCB1000-6	1000		6	30	
CPEGCB1000-12	1000		12	20	
CPEGCB2000-12	2000		12	20	
CPEALA0050-1	AL-A		50	1	100
CPEALA0100-1			100	1	100
CPEALA0200-3			200	3	50
CPEALA0500-3		500	3	50	
CPEALA0500-6		500	6	30	
CPEALA1000-6		1000	6	30	
CPEALB0050-1	AL-B	50	1	100	
CPEALB0100-1		100	1	100	
CPEALB0200-3		200	3	50	
CPEALB0500-3		500	3	50	
CPEALB0500-6		500	6	30	
CPEALB1000-6		1000	6	30	
CPEALN0050-1	AL-N	50	1	100	
CPEALN0100-1		100	1	100	
CPEALN0200-3		200	3	50	
CPEALN0500-3		500	3	50	
CPEALN0500-6		500	6	30	
CPEALN1000-6		1000	6	30	
CPEGCNH20202-3	GCB/NH ₂	250/250	3	50	
CPEGCNH20305-6		300/500	6	30	
CPEGCNH20505-6		500/500	6	30	
CPEGCBPSA0202-3	GCB/PSA	250/250	3	50	
CPEGCBPSA0305-6		300/500	6	30	
CPEGCBPSA0505-6		500/500	6	30	

(*) Other sizes and sorbents are available under request.

Equivalence Table

Sorbent Phase	Chmlab	Waters	Agilent	Phenomenex	Supelco
Silica	ChromPACK Si	Sep-Pak Si	Bond Elut Si	Strata Si-1	Supelclean LC-Si
C18	ChromPACK C18	Sep-Pak tC18	Bond Elut C18	Strata C18-E	Supelclean ENVI-18
C18-ne	ChromPACK C18-ne	Sep-Pak C18	Bond Elut C18OH	Strata C18-U	-
C8	ChromPACK C8	Sep-Pak C8	Bond Elut C8	Strata C8	Supelclean ENVI-8
CN	ChromPACK CN	Sep-Pak CN	Bond Elut CN-E	Strata CN	Supelclean LC-CN
NH ₂	ChromPACK NH ₂	Sep-Pak NH ₂	Bond Elut NH ₂	Strata NH ₂	Supelclean LC-NH ₂
PSA	ChromPACK PSA	-	Bond Elut PSA	Strata PSA	Supelclean PSA
SAX	ChromPACK SAX	-	Bond Elut SAX	Strata SAX	Supelclean LC-SAX
SCX	ChromPACK SCX	-	Bond Elut SCX	Strata SCX	Supelclean LC-SCX
HLB	ChromPACK PLS	Oasis HLB	Bond Elut Plexa	Strata-X	Supel-Select HLB
MCX	ChromPACK MCX	Oasis MCX	Bond Elut PCX	Strata-XC	Supel-Select SCX
MAX	ChromPACK MAX	Oasis MAX	Bond Elut PAX	Strata-XA	Supel-Select SAX
Florisil	ChromPACK Florisil	Sep-Pak FL	Bond Elut FL	Strata FL-PR	Supelclean LC-Florisil
GCB	ChromPACK GCB	-	Bond Elut Carbon	-	Supelclean ENVI Carb
Alumina-A	ChromPACK Alumina-A	Sep-Pak Alumina-A	Bond Elut Alumina A	Strata Alumina-A	Supelclean LC-Alumina-A
Alumina-B	ChromPACK Alumina-B	Sep-Pak Alumina-B	Bond Elut Alumina B	Strata Alumina-B	Supelclean LC-Alumina-B
Alumina-N	ChromPACK Alumina-N	Sep-Pak Alumina-N	Bond Elut Alumina N	Strata Alumina-N	Supelclean LC-Alumina-N
GCB/NH ₂	ChromPACK GCB/NH ₂	-	Bond Elut/NH ₂	-	Supelclean ENVI Carb/NH ₂
GCB/PSA	ChromPACK GCB/PSA	-	Bond Elut/PSA	-	Supelclean ENVI Carb-II/PSA

4.7 QuEChERS

Quick, Easy, Cheap, Effective, Rugged and Safe

A simplified method of sample preparation for pesticide analysis.

QuEChERS extraction method is designed for multi-residue pesticide analysis of fruits and vegetables coupled with a clean-up method that removes sugars, lipids, organic acids, sterols, proteins, pigments, and excess water.

This technique offers a user-friendly alternative to traditional liquid-liquid and solid-phase extractions.

Compared to sample preparation traditional techniques, CHM® solutions offer:

- Saving time for sample preparation
- Economic and effective sample preparation
- Reliability and easy usage

The process involves two simple steps; Firstly, the homogenized samples are extracted and partitioned using an organic solvent and salt solution. Then, the supernatant is further extracted and cleaned using a dispersive solid-phase extraction technique.

Currently, there are four QuEChERS method variants:

- Original method: Introduced in 2003, it uses NaCl to improve the extraction.
- Dispersive method AOAC 2007.01 according to the Association of Analytical Communities (AOAC), it uses Sodium Acetate as a buffer instead of NaCl.
- Double phase variant: It uses PSA and GBC (Graphitized Carbon Black) to remove high levels of pigments, such as chlorophyll or carotenoid and sterols in the final extract without the loss of planar pesticides using a mixture of Acetone: Toluene (3:1)
- European method EN15662:2008: Similar method to AOAC except for the use of NaCl, Sodium Citrate Dihydrate and Sodium Citrate Sesquihydrate instead of Sodium Acetate.



QuEChERS General Procedures

AOAC2007.01 METHOD

Homogenize sample



Weigh 15 g and transfer into 50 ml tube



Add 15 ml acetic acid and internal standard solution



Shake vigorously for 1 min



Add buffering salts and centrifuge



Transfer supernatant to SPE tube



Shake vigorously for 30 seconds and centrifuge



Transfer supernatant for chromatography analysis
(GC/MS or LC/MS)

EN 15662:2008 METHOD

Homogenize sample



Weigh 10 g and transfer into 50 ml tube



Add 10 ml acetic acid and internal standard solution



Shake vigorously for 1 min



Add buffering salts and centrifuge



Transfer supernatant to SPE tube



Shake vigorously for 30 seconds and centrifuge



Transfer supernatant for chromatography analysis
(GC/MS or LC/MS)



Technical Specifications and Order Information

Order Number	Description	Specifications	Quantity / Box
CHM® QuEChERS AOAC 2007.01 Method			
QE50020	Extraction tube. Tube composition: 6 g MgSO ₄ 1.5 g NaOAc	50 ml tube	25
QE02031	PSA Clean-up tube 1: 50 mg PSA, 150 mg MgSO ₄	2 ml tube, 1 ml sample	100
QE15031	PSA Clean-up tube 2: 400 mg PSA, 1200 mg MgSO ₄	15 ml tube, 8 ml sample	50
QE02033	PSA/C18 Clean-up tube 1: 50 mg PSA, 50 mg C18, 150 mg MgSO ₄	2 ml tube, 1 ml sample	100
QE15033	PSA/C18 Clean-up tube 2: 400 mg PSA, 400 mg C18, 1200 mg MgSO ₄	15 ml tube, 8ml sample	50
QE15040	PSA/C18/GCB Clean-up tube 1: 50 mg PSA, 50 mg C18, 50 mg GCB, 150 mg MgSO ₄	2 ml tube, 1 ml sample	100
QE15040	PSA/C18/GCB Clean-up tube 2: 400 mg PSA, 400 mg C18, 400 mg GCB, 1200 mg MgSO ₄	15 ml tube, 8 ml sample	50
CHM® QuEChERS EN 15662:2008 Method			
QE50010	Extraction tube. Tube composition: 4 g MgSO ₄ 1 g NaCl 0.5 g Dibasic sodium citrate sesquihydrate 1 g Sodium Citrate	50 ml tube	25
QE02030	PSA Clean-up tube 1: 25 mg PSA , 150 mg MgSO ₄	2 ml tube, 1 ml sample	100
QE15022	PSA Clean-up tube 2: 150 mg PSA , 900 mg MgSO ₄	15 ml tube, 8 ml sample	50
QE20020	PSA/GCB Clean-up tube 1: 25 mg PSA , 25 mg GCB, 150 mg MgSO ₄	2 ml tube, 1 ml sample	100
QE15020	PSA/GCB Clean-up tube 2: 150 mg PSA , 15 mg GCB, 900 mg MgSO ₄	15 ml tube, 8ml sample	50
QE20024	PSA/GCB Clean-up tube 1: 25 mg PSA, 7,5 mg GCB, 150 mg MgSO ₄	2 ml tube, 1 ml sample	100
QE15024	PSA/GCB Clean-up tube 2: 150 mg PSA, 45 mg GCB, 900 mg MgSO ₄	15 ml tube, 8 ml sample	50
QE02032	PSA/C18 Clean-up tube 1: 25 mg PSA, 25 mg C18, 150 mg MgSO ₄	2 ml tube, 1 ml sample	100
QE15032	PSA/C18 Clean-up tube 2: 150 mg PSA, 150 mg C18, 900 mg MgSO ₄	15 ml tube, 8 ml sample	50



05

INDUSTRIAL FILTRATION

5.1	Plain filter paper	166
5.2	Crêped filter paper	168
5.3	Filter boards	169



05

INDUSTRIAL FILTRATION

CHMLAB offers a complete selection of filter papers and filter boards used in industrial filtration processes for the production of all kinds of liquids. Liquids such as: food products, beverages, pharmaceutical industry, chemical products, electroplating, edible or industrial oils, technical fats, biodiesel, cosmetics, inks, etc.

Each of these filter media are adapted to different industrial products, such as filtration speed, flow rate, retention, load capacity and other physical features.

This range consists of the following filter media:

- Plain (smooth) filter papers between 50 and 650 g/m²
- Crêped filter papers between 50 and 240 g/m²
- Filter boards for depth filtration by coarse, clarifying, fine and even sterilizing filtration

CHMLAB puts at your disposal any required format: sheets with or without holes, circles, discs or rolls of requested width.

Types of paper

Plain filter papers (P)

These papers are designed to meet specific filtration requirements.

Crêped filter papers (C)

They have larger filtration surfaces resulting in higher filtration speed. Also, the larger filtration surfaces offer greater particulate holding capacity compared to plain surface papers.

Filter boards (B)

These filters are manufactured according to specific applications and they can be produced in disc or sheet formats, with one or more holes to use in filter press systems.

Applications

Food & Beverage

Pharmaceutical

Cosmetics

Chemical Industry

Microelectronics

Electroplating

How to find the correct code

Due to the wide variety of paper grades, formats and dimensions, the order number list is very extensive. The following guideline will help you to find the right order number.

I Industrial paper

P Plain paper

C Crêped paper

B Filter boards

XXX Basis weight (g/m²)

Example:

IP085 Industrial paper **P**lain **85** g/m²

When different types of filters belong to the same group, with the same basis weight, letters at the end of the code help to differentiate them.

Example:

IC090M

Industrial paper **C**rêped **90** g option **M**edium filtration speed

IC090F

Industrial paper **C**rêped **90** g option **F**ast filtration speed

5.1 Plain filter papers

Order Information

Grade	Basis Weight (g/m ²)	Thickness (mm)	Filtration Speed (s/10 ml)
IP085	85	0.18	Medium
IP090	90	0.19	Very slow
IP100	100	0.24	Medium
IP125	115	0.25	Fast
IP140	140	0.29	Fast
IP150	150	0.30	Very slow
IP160M	160	0.38	Medium
IP160F	160	0.47	Extra-Fast
IP190	185	0.41	Medium
IP250	250	0.58	Fast
IP300	300	0.65	Medium
IP320	320	0.88	Medium
IP350	350	0.78	Medium
IP375	375	0.98	Fast
IP390	390	0.93	Medium
IP400	400	0.75	Medium
IP450	450	0.99	Slow
IP500	500	1.13	Slow
IP650	650	1.5	Slow
IP-AC	160	0.40 - 0.50	Slow

INDUSTRIAL FILTRATION



Grade	Applications
IP085	Pre-filtration of white wines, liquors and distilled before filter boards, sugar juices, salted solutions
IP090	Retention of active carbon particles, mineral water, boiler water, final polishment of different liquids
IP100	Filtration of essences, Pre-filtration of red wine and vinegar before filter boards
IP125	Filtration of fine chemistry products
IP140	Filtration of resins in high temperature, food additives, lacquers
IP150	Filtration of dirty water for boiler, final clarification of clear liquids, Polishing of fine chemical products
IP160M	Turbid liquids, Vegetable extracts, Fruit juices, cosmetic products,
IP160F	Animal fats, butter, margarine, very dense essential oils, syrups, Filtration of liquids with high load precipitates
IP190	Polishment of olive oil before bottled, chemical products, absorption of excess ink in the print industry. In the galvanic industry for filtration of manganese baths, food additives
IP250	Standard quality for clarification of liquids, electrical transformer oils, large motor oils, cosmetics, in galvanic Industry for filtration of manganese, copper, bright nickel, zinc and nickel baths
IP300	Dirty mineral oils, Hydrocarbons, lacquers, high-temperature resins, in the galvanic industry for filtration of copper and zinc baths, machine oils
IP320	Filtration of turbine oils, electrical transformer oils, motor lubricants, dirty liquids
IP350	Filtration of fine chemicals
IP375	Very dense and dirty oils, in the galvanic industry for silver and zinc baths, dense resins, lacquers, essential oils, syrups, animal fats, clarification of bio-diesel
IP390	High absorption of liquids, filtration of mineral oils, electrical engines oils, electrical transformer oils, motor and turbines oils
IP400	Filtration of fine chemicals, mineral waters, nutritional additives, clear liquids with low density, in galvanic for filtration of copper baths
IP450	Filtration and clarification in the chemical industry, alcohol and spirits, water for boilers, retention of particles
IP500	Filtration of olive oil, mineral water, retention of particles as active carbon, diatomaceous earths or other used in the food industry, in galvanic industry for silver and nickel sulfamate baths
IP650	Mineral water, water for boiled, alcohols, high absorption works
IP-AC	Chemical products, clarification and decoloration of industrial liquids, in the galvanic industry for filtration of lead, cadmium, ferrum, copper and bright nickel baths

5.2 Crêped filter papers

Order Information

Grade	Basis Weight (g/m ²)	Thickness (mm)	Filtration Speed (s/10 ml)
IC050	50	0.185	Fast
IC060	60	0.250	Very fast
IC064	64	0.165	Very fast
IC073	73	0.285	Fast
IC090M	90	0.330	Medium
IC090F	90	0.390	Very fast
IC110	110	0.320	Medium
IC132	132	0.550	Very fast
IC140	140	0.450	Fast
IC156	156	0.550	Extra-fast
IC160	160	0.450	Medium
IC185	185	0.650	Medium
IC240	240	0.780	Fast

Grade	Applications
IC050	Retention of textile fibers, absorption, syrups in low concentration
IC060	Emulsions, filtration of infusions, industrial ingredients, musts, in galvanic industry for filtration of lead, ferrum, iridium, cooper, nickel and silver baths
IC064	Sugar solutions in low concentration, filtration of juices
IC073	Ceramic colorants, gold and copper baths in the galvanic industry, soft basic or acid solutions, filtration of edible oils
IC090M	Gold and copper baths, sunflower oil, musts, pre-filtration of wines before filter sheets, fruits juices
IC090F	Dense edible oils, in the galvanic industry for cadmium, nickel, silver and nickel alloys dense fruit juices, sludge drying in filter press
IC110	Sunflower oil, technical fats, sludge drying in a filter press, gold handling in mines
IC132	Filtration of lacquers, emulsions, Animal fats, gelatines, dense essential oils
IC140	Pre-filtration of wines, in the galvanic industry for copper, nickel and zinc baths, technical fats, mineral oils
IC156	Syrups, Essential oils, Butters and margarine
IC160	Hair lotions, distilled and liquors, musts, per-filtration of red wines, absorption by transversal capillarity fruit juices
IC185	Polishment of extra-virgin olive oil, glycerin in high temperature, in the galvanic industry for copper, nickel, and zinc baths, contaminated industrial liquids, filtration of dyestuff, clarification of industrial chip pan oil
IC240	Polishment of extra-virgin olive oil packing in glass bottles, lacquers, absorbent strips by capillarization of parfums dispensers

5.3 Filter boards

Order Information

Grade	Basis Weight (g/m ²)	Thickness (mm)	Retention Range (µm)	Flow rate with water Δp= 1 bar [L/m ² x min]	Ash content (%)	Filtration Type
IB0700	700 - 855	3.35 - 3.80	25 - 40	1723 - 3064*	<1.0	Coarse
IB0720	720 - 855	3.10 - 3.50	10 - 30	1583 - 2815*	16.0 - 22.0	Coarse
IB1030	1030 - 1270	3.50 - 4.0	2.0 - 7.0	485 - 885	34.5 - 41.5	Clarifying filtration
IB1110	1110 - 1360	3.50 - 4.0	4.0 - 1.0	240 - 505	38.0 - 46.0	Clarifying filtration
IB1200	1200 - 1400	3.40 - 3.80	1.5 - 0.6	115 - 445	39.0 - 45.0	Fine filtration
IB1300	1300 - 1500	3.70 - 3.90	0.8 - 0.5	69 - 81	46.1 - 51.1	Sterile filtration
IB1350	1350 - 1550	3.50 - 3.90	0.7 - 0.4	50 - 65	36.0 - 42.0	Sterile filtration
IB1400	1400 - 1600	3.50 - 4.0	0.4 - 0.2	43 - 52	47.5 - 42.5	Sterile filtration

Grade	Applications
IB0700	Paints, inks, glues, process water, biodiesel, high viscosity solutions etc.
IB0720	Paints, inks, glues, process water, biodiesel, high viscosity solutions etc.
IB1030	Food and beverages (e.g. beer, wine, juice), fine chemicals, cosmetic extracts, gelatine, sugar solutions, etc
IB1110	Food and beverages (e.g. beer, wine, juice), fine chemicals, cosmetic extracts, gelatine, sugar solutions, etc
IB1200	Food and beverages (e.g. beer, wine, juice), fine chemicals, cosmetic extracts, gelatine, sugar solutions, etc
IB1300	Food and beverages (e.g. beer, wine, juice), fine chemicals, cosmetic extracts, gelatine, sugar solutions, etc
IB1350	Food and beverages (e.g. beer, wine, juice), fine chemicals, cosmetic extracts, gelatine, sugar solutions, etc
IB1400	Food and beverages (e.g. beer, wine, juice), fine chemicals, cosmetic extracts, gelatine, sugar solutions, etc

06

CAPSULE FILTERS

CHM® CapFIL Capsule filters	173
6.1 CHM® TRI-CLAMP Capsule filter CapFIL	174
6.2 CHM® Hose Barb capsule filter	176
6.3 CHM® 1/4" NPT capsule filter	178

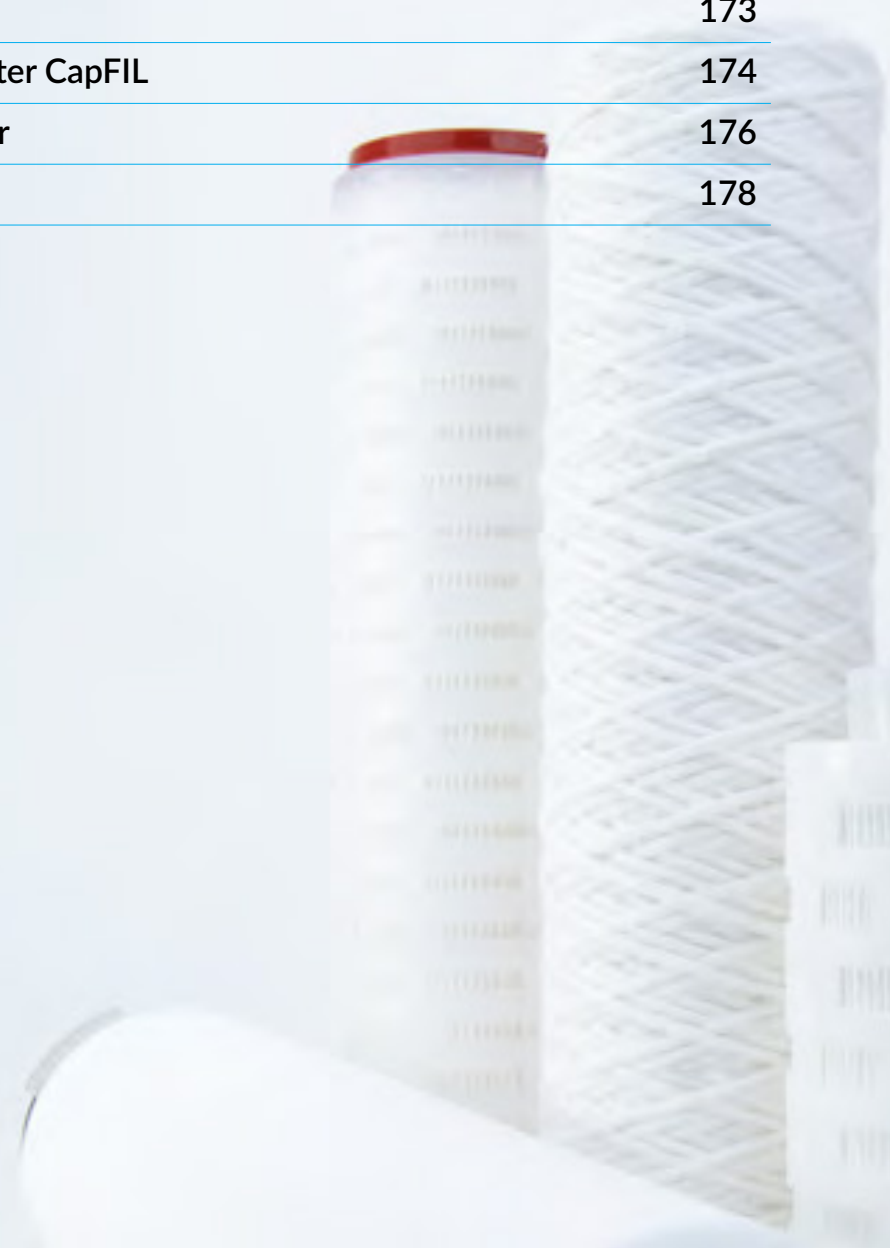



CAPSULE FILTERS

06

CAPSULE FILTERS



CAPSULE FILTERS

CHM® CapFIL Capsule filters

CHM® CapFIL capsule filters have been specially designed for simple, quick, and efficient particles or bacteria filtration of aqueous or solvent solutions and gases used in laboratory, pilot-plant and small-scale applications. They are ready-to-use filters, eliminating the need to disassemble, clean and reassemble filter housings.

CHM® CapFIL capsule filters contain no adhesives, binders, or surfactants. Thanks to their serial layer filter design the CapFIL increase their throughput and extend their working life.

All capsules containing membrane media are pre-flushed with purified water to reduce extractables.

The all-polypropylene construction provides excellent chemical compatibility and superior flow per unit area as compared to other membrane cartridges.

Features

Combine a full range of filter media:

- Polypropylene (PP)
 - Polyethersulfone (PES)
 - Polytetrafluoroethylene (PTFE)
 - Mixed Cellulose Esters (MCE)
 - Polyamide 66 (Nylon)
 - Glass fiber
- and pore size ratings to cover numerous applications.

All the materials used in the CapFIL manufacturing process meets the USP Class VI Plastics biological reactivity tests.

Manufactured in a Clean Room Environment

Offer high reliability, security and convenience for small to medium batch processing applications



6.1 CHM® TRI-CLAMP Capsule filter CapFIL

Features

- Low hold-up volume
- Good resistance to pressure
- Eco-friendly and cost-effective
- Smart, disposable and safe

Applications

- Beverage filtration: wine, beer and other drinks
- Water filtration
- Gas and air filtration

Technical Specifications

Membrane	Polypropylene (PP) Polyethersulfone (PES) Polytetrafluoroethylene (PTFE) Mixed Esters (MCE) Polyamide 66 (Nylon) Glass fiber
Support & Housing	Polypropylene
Sealing	Thermal bonding, No adhesives
Pore size (µm)	0.01, 0.1, 0.22, 0.45, 1.0, 3.0, 5.0
Max. Pressure for liquids	3.5 bar at 23 °C 3.0 bar at 60 °C
Max. Pressure for gas & air	3.0 bar at 23 °C 2.5 bar at 60 °C
Filtration area	≥ 0.2 m ²
Sterilization	By autoclaving 3 autoclave cycles of 30 minutes at 123 °C
Grade	Food & Beverage



CAPSULE FILTERS

Order Information

Grade	Code	Membrane type	Code	Pore size (µm)	Code	Length (inch)	Code	Connection		Code	Packing
CTF	PE	PES	001	0.01(for Air)	05	5	FS	Inlet	Tri-Clamp	U	1 unit
TRI-CLAMP	NY	Nylon	010	0.1				Outlet	Tri-Clamp		
	PA	Hydrophobic PTFE for air	022	0.22				Drainage	Silicone		
	PH	Hydrophobic PTFE	045	0.45			FE	Inlet	Tri-Clamp		
	PL	Hydrophilic PTFE	100	1.0				Outlet	Tri-Clamp		
	CN	Mixed Cellulose Esters	300	3.0				Drainage	EPDM		
	PP	Polypropylene	500	5.0							
	GF	Glass fiber									

Example

CTFPE022-05-FS-U:

CAPSULE FILTER in polypropylene housing

Membrane: Polyethersulfone (PES)

Pore Size: 0.22 µm

Length: 5 inch

Inlet: Tri-clamp

Outlet: Tri-clam

Drainage: Silicone

Pack: 1 unit

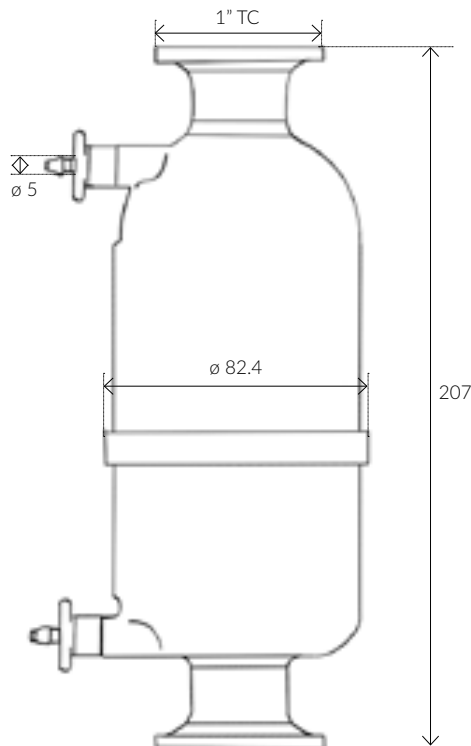

6.2 CHM® Hose Barb capsule filter

Features

Low hold-up volume
Good mechanical strength
Eco-friendly and cost-effective
Smart, disposable and safe

Applications

Beverage filtration: wine, beer and other drinks
Water filtration
Gas and air filtration

Technical Specifications

Membrane	Polypropylene (PP) Polyethersulfone (PES) Polytetrafluoroethylene (PTFE) Mixed Esters (MCE) Polyamide 66 (Nylon) Glass fiber
Support & Housing	Polypropylene
Sealing	Thermal bonding, No adhesives
Pore size (µm)	0.01, 0.1, 0.22, 0.45, 1.0, 3.0, 5.0
Max. Pressure for liquids	3.5 bar at 23 °C 3.0 bar at 60 °C
Max. Pressure for gas & air	3.0 bar at 23 °C 2.5 bar at 60 °C
Filtration area	≥ 0.2 m ²
Sterilization	By autoclaving 3 autoclave cycles of 30 minutes at 123 °C
Grade	Food & Beverage

Order Information

Grade	Code	Membrane type	Code	Pore size (µm)	Code	Length (inch)	Code	Connection	Code	Packing
CHF	PE	PES	001	0.01 (for Air)	05	5	DS	Inlet/ Outlet	U	1 unit
HOSE BARB	NY	Nylon	010	0.1	10	10	DS	Outlet	7.5 mm	
	PA	Hydrophobic PTFE for air		022				0.22	Drainage	
	PH	Hydrophobic PTFE	045	0.45				DE	Inlet/ Outlet	
	PL	Hydrophilic PTFE	100	1.0			Outlet		7.5 mm	
	CN	Mixed Cellulose Esters	300	3.0			Drainage		EPDM	
	PP	Polypropylene	500	5.0						
	GF	Glass fiber								

Example

CHFPE022-10-DS-U:

CAPSULE FILTER Hose Barb in polypropylene housing

Membrane: Polyethersulfone (PES)

Pore Size: 0.22 µm

Length: 10 inch

Inlet: 13.6 Hose barb

Outlet: 7.5 hose barb

Drainage: 7.5 mm Silicone

Pack: 1 unit

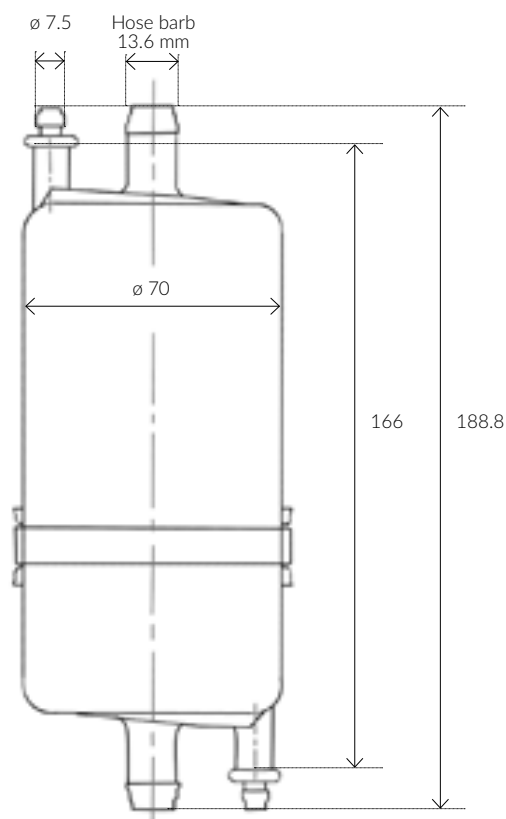

6.3 CHM® 1/4" NPT capsule filter

Features

- Low hold-up volume
- Smart, disposable and safe
- Eco-friendly and cost-effective

Applications

- Beverage filtration: wine, beer and other drinks
- Water filtration
- Gas and air filtration

Technical Specifications

Membrane	Polypropylene (PP) Polyethersulfone (PES) Polytetrafluoroethylene (PTFE) Mixed Esters (MCE) Polyamide 66 (Nylon) Glass fiber
Support & Housing	Polypropylene
Sealing	Thermal bonding, No adhesives
Pore size (µm)	0.01, 0.1, 0.22, 0.45, 1.0, 3.0, 5.0
Max. Pressure for liquids	3.5 bar at 23 °C 3.0 bar at 60 °C
Max. Pressure for gas & air	3.0 bar at 23 °C 2.5 bar at 60 °C
Dimensions	Diameter: 67 mm Length: 2.5", 5", 10" Inlet/Outlet: 1/4" NPT Vent/Drainage: 1/8" NPT
Filtration area	2.5": ≥ 1 m ² 5": ≥ 2 m ² 10": ≥ 3 m ²
Sterilization	By autoclaving 3 autoclave cycles of 30 minutes at 123 °C
Grade	Food & Beverage

Order Information

Grade	Code	Membrane type	Code	Pore size (µm)	Code	Length (inch)	Code	Connection	Code	Packing
1/4" NPT	PE	PES	001	0.01 (for Air)	2.5	02	Common	Inlet/Outlet: 1/4" MNPT Vent/Drain: 1/8" MNPT	U	1 unit
	NY	Nylon	010	0.1	5	05				
	PA	Hydrophobic PTFE for air	022	0.22	10	10	HS	H type for pipe heard connection adapter. EPDM O-ring		
	PH	Hydrophobic PTFE	045	0.45			WS	W type for pipe heard connection adapter. Silicone O-ring		
	PL	Hydrophilic PTFE	100	1.0			WS	W type for pipe heard connection adapter. EPDM O-ring		
	CN	Mixed Cellulose Esters	300	3.0			WS	W type for pipe heard connection adapter. EPDM O-ring		
	CN	Mixed Cellulose Esters	500	5.0			WS	W type for pipe heard connection adapter. EPDM O-ring		
	PP	Polypropylene								
	AP	Absolute PP								
	MP	Multi-layer PP								
GF	Glass fiber									

Example

CHFCN045-02-WS-U:

CAPSULE FILTER Mixed cellulose Esters (MCE) in polypropylene housing

Membrane: Mixed cellulose Esters (MCE)

Pore Size: 0.45 μm

Length: 2.5 inch

Inlet/outlet: 1/4" MNPT

Vent/Drain: 1/8" MNPT

W type of pipe heard connection adapter

Silicone O-ring

Pack: 1 unit

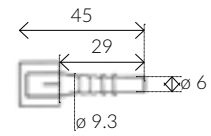
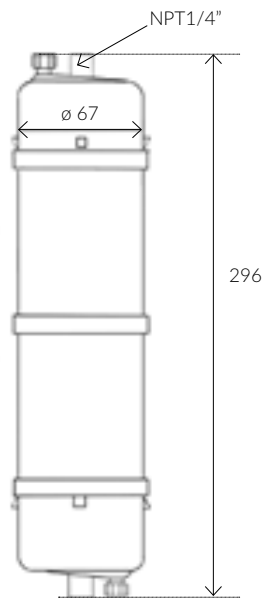
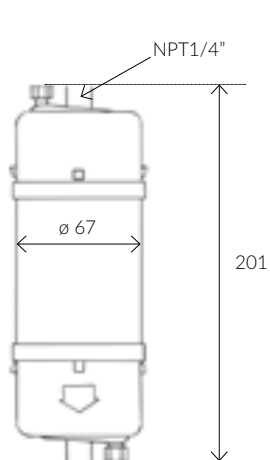

H-type (6-8 mm) adapter

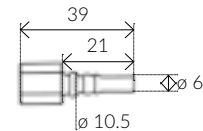

W-type (6-9.5 mm) adapter

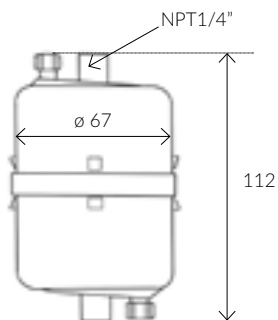

A

APPENDIX

A. 1	Chemical compatibility table	182
A. 2	Equivalence table	186



A.1 Chemical Compatibility table

Filter Media

Solvents	Cel. Acetate	Cel. Nitrate	Glass fiber	PP	Polyamide	PTFE	PES
Acetone	x	x	✓	✓	✓	✓	x
Acetonitrile	x	x	?	✓	○	✓	✓
Amyl alcohol	✓	x	✓	✓	✓	✓	x
Amyl acetate	○	x	✓	✓	✓	✓	○
Aniline	x	x	?	✓	✓	✓	✓
Benzene	○	✓	✓	○	✓	✓	✓
Benzyl alcohol	○	✓	x	✓	○	✓	x
Bromoform	x	✓	✓	✓	✓	✓	?
N-Butyl acetate	○	x	✓	✓	✓	✓	○
Butyl Alcohol	✓	✓	✓	✓	✓	✓	✓
Carbon tetrachloride	○	✓	x	✓	✓	✓	✓
Chloroform	x	✓	✓	○	○	✓	x
Cyclohexane	○	○	✓	✓	✓	✓	x
Cyclohexanane	x	x	✓	✓	✓	✓	x
Ethoxyethanol (Cellosolve)	x	x	✓	✓	✓	✓	✓
Ethyl alcohol 90%	✓	○	✓	✓	✓	✓	✓
Ethylene dichloride	x	x	✓	✓	○	✓	x
Dimethyl acetamide	x	x	✓	x	✓	✓	?
Diethyl ether	✓	x	✓	✓	✓	✓	?
Dimethyl formamide	x	x	✓	✓	○	✓	x
Dimethyl sulfoxide (DMSO)	x	x	✓	✓	✓	✓	x
Dioxane	x	x	✓	✓	✓	✓	○
Ethanol 98%	✓	○	✓	✓	✓	✓	✓
Ethyl acetate	x	x	✓	○	○	✓	○
Ethyl ether	○	○	✓	✓	✓	✓	✓
Ethylene glycol	✓	○	✓	✓	✓	✓	✓
Formamide	?	?	✓	✓	?	✓	?
Formaldehyde 37%	○	x	?	✓	✓	✓	✓
Freon TF	✓	✓	✓	✓	✓	✓	✓
Gasoline	✓	✓	✓	○	✓	✓	?
Glycerine	✓	✓	✓	✓	✓	✓	✓
n-Heptano	✓	?	✓	✓	✓	✓	✓
n-Hexanol	✓	✓	✓	✓	✓	✓	✓
Isobutyl alcohol	✓	✓	x	✓	✓	✓	✓
Isopropanol	○	○	✓	✓	✓	✓	✓
Isopropil acetato	x	x	✓	✓	✓	✓	✓
Isopropil éter	✓	✓	?	✓	?	✓	?
Kerosene	✓	✓	✓	✓	✓	✓	✓
Metanol 98%	x	x	✓	✓	○	✓	✓
Methyl acetate	x	x	✓	✓	✓	✓	x
Methylene chloride	x	x	✓	✓	○	✓	x
Methyl etil ketone	x	x	✓	✓	✓	✓	x
Methyl isobutyl ketone	x	x	✓	✓	✓	✓	x
Monochlorobenzene	?	?	✓	?	✓	✓	?
Nitrobenzene	x	x	x	✓	✓	✓	x
N-Pentane	✓	✓	✓	○	✓	✓	✓
Perchlorethylene	○	✓	x	✓	✓	✓	x
Phenol	x	✓	?	✓	✓	✓	x
Pyridine	x	x	✓	✓	✓	✓	x
Perchlorethylene	✓	✓	x	✓	✓	✓	x
Propanol	✓	✓	✓	✓	✓	✓	✓
Propylene glycol	?	?	?	✓	✓	✓	○
Pyridine	x	x	✓	✓	✓	✓	x
Tetrahydrofuran	x	x	○	○	○	○	x

Housing

PVDF	Reg. Cel.	Polyester	PC	Acrylic mod.	Polysulfone	Polystyrene	PP
x	✓	✓	○	x	x	x	✓
✓	✓	✓	x	x	x	x	✓
✓	✓	?	?	x	✓	x	✓
✓	✓	✓	✓	x	x	x	✓
✓	✓	✓	x	?	x	?	✓
○	✓	✓	○	x	x	x	○
✓	✓	✓	○	✓	✓	x	✓
?	?	✓	x	?	x	?	✓
✓	✓	✓	✓	x	x	x	✓
✓	✓	✓	✓	✓	✓	?	✓
✓	✓	✓	○	x	x	x	✓
○	✓	✓	x	x	○	x	○
x	✓	✓	○	x	✓	?	✓
x	✓	✓	○	x	x	x	✓
✓	✓	✓	✓	x	x	?	✓
✓	?	✓	✓	○	✓	x	✓
○	✓	✓	x	?	x	?	○
?	✓	✓	x	x	x	x	x
✓	✓	✓	✓	x	x	x	✓
x	○	✓	x	x	x	x	✓
x	✓	✓	x	x	x	x	✓
✓	✓	✓	x	x	x	x	✓
✓	✓	✓	✓	x	x	x	✓
✓	✓	?	?	?	?	?	○
✓	✓	✓	✓	x	✓	x	✓
✓	✓	✓	✓	?	✓	?	✓
?	?	x	x	?	?	?	✓
✓	○	✓	✓	x	✓	x	✓
✓	?	✓	✓	○	✓	x	✓
✓	✓	✓	✓	x	✓	x	○
✓	✓	✓	✓	?	✓	?	✓
✓	✓	✓	?	?	?	?	✓
✓	✓	✓	✓	x	✓	x	✓
✓	✓	✓	✓	✓	✓	✓	?
✓	✓	✓	✓	?	✓	?	✓
x	✓	✓	✓	x	x	x	✓
✓	✓	✓	x	?	?	?	✓
✓	✓	✓	✓	x	x	x	✓
✓	✓	✓	✓	✓	✓	✓	✓
✓	✓	✓	x	x	x	x	✓
✓	✓	✓	x	x	x	x	✓
x	✓	✓	○	x	x	x	✓
x	✓	?	○	x	x	x	✓
?	✓	?	x	?	?	?	?
✓	✓	✓	x	x	x	x	✓
✓	✓	✓	✓	x	✓	x	○
?	✓	?	✓	x	○	x	✓
✓	✓	✓	✓	?	?	?	✓
x	✓	✓	x	x	x	x	✓
○	✓	?	✓	x	○	x	✓
✓	✓	✓	✓	?	✓	?	✓
✓	?	?	?	?	?	?	✓
x	✓	✓	x	x	x	x	✓
○	✓	?	✓	x	○	x	✓
✓	✓	✓	✓	?	✓	?	✓
✓	?	?	?	?	?	?	✓
x	✓	✓	x	x	x	x	✓
○	✓	✓	x	x	x	x	○

Toluene	○	✓	✓	○	✓	✓	x
Turpentine	✓	✓	✓	○	✓	✓	x
Trichloroethane	○	✓	?	✓	✓	✓	✓
Trichlorethylene	✓	✓	x	○	✓	○	✓
Triethylamine	✓	○	✓	✓	✓	✓	?
Water	✓	✓	✓	✓	✓	*	✓
Xylene	✓	✓	✓	○	✓	✓	○

Filter Media

Acids	Cel. Acetate	Cel. Nitrate	Glass fiber	PP	Polyamide	PTFE	PES
Acetic acid 5%	✓	✓	✓	✓	✓	✓	✓
Acetic acid 10%	✓	✓	✓	✓	○	✓	✓
Acetic acid 25%	✓	✓	?	✓	○	✓	x
Acetic acid 96%	x	x	✓	✓	x	✓	✓
Boric acid	✓	✓	?	✓	○	✓	?
Hydrofluoric acid 10%	x	x	x	✓	x	✓	?
Hydrofluoric acid 25%	✓	○	x	✓	x	✓	?
Hydrofluoric acid 35%	✓	○	x	✓	x	✓	?
Hydrofluoric acid 50%	✓	○	x	x	x	✓	✓
Phosphoric acid 25%	✓	○	?	✓	x	✓	✓
Phosphoric acid 85%	○	○	?	✓	x	✓	?
Nitric acid 25%	x	○	?	✓	x	✓	✓
Nitric acid 65%	x	x	?	✓	x	✓	✓
Hydrochloric acid 25%	x	○	?	✓	x	✓	✓
Hydrochloric acid 37%	x	x	?	✓	x	✓	✓
Hydrochloric acid 98%	x	x	?	✓	x	✓	✓
Perchloric acid 60%	○	✓	?	✓	?	✓	✓
Sulfuric acid 25%	x	○	✓	✓	x	✓	✓
Sulfuric acid 98%	x	x	?	✓	x	✓	x
Trichloroacetic acid 25%	x	○	?	✓	x	✓	?

Filter Media

Bases	Cel. Acetate	Cel. Nitrate	Glass fiber	PP	Polyamide	PTFE	PES
Ammonium, 1N	✓	✓	✓	?	✓	✓	✓
Ammonium hydroxide 25%	x	○	○	✓	✓	○	✓
Potassium hydroxide 32%	x	x	○	✓	○	✓	✓
Sodium hydroxide 32%	x	x	○	✓	○	✓	✓

Filter Media

Aqueous Solutions	Cel. Acetate	Cel. Nitrate	Glass fiber	PP	Polyamide	PTFE	PES
Formalin 30%	○	✓	✓	?	○	✓	✓
Saline solution	✓	✓	✓	✓	✓	*	✓
Sodium hypochlorite 5%	✓	○	✓	?	○	✓	?
Hydrogen peroxide 35%	✓	✓	?	?	○	✓	?

Filter Media

Oils and others	Cel. Acetate	Cel. Nitrate	Glass fiber	PP	Polyamide	PTFE	PES
Cotton seed oil	✓	✓	✓	✓	✓	✓	?
Freon TF	✓	✓	✓	✓	✓	✓	✓
Kodak KMER FTFR	x	x	x	?	✓	✓	?
Lubricant oil	✓	✓	✓	✓	✓	✓	x
Peanut oil	✓	✓	✓	✓	✓	✓	✓
Petroleum oil	?	✓	○	○	?	✓	○
Sesame oil	✓	✓	✓	✓	✓	✓	✓
Shipley (As-111,340, 1350)	x	x	x	✓	✓	✓	?
Silicone oils	✓	✓	✓	✓	✓	✓	✓
Waycoat 59	x	x	✓	✓	✓	✓	?

✓ = compatible

○ = limited compatibility

x = not compatible

? = not tested

✓	✓	✓	○	x	x	x	○
✓	?	✓	✓	?	✓	?	?
?	✓	?	?	x	x	x	✓
✓	✓	✓	x	x	x	x	○
?	✓	✓	○	?	x	?	?
✓	✓	✓	✓	✓	✓	✓	✓
✓	✓	✓	✓	x	x	x	✓

Housing

PVDF	Reg. Cel.	Polyester	PC	Acrylic mod.	Polysulfone	Polystyrene	PP
✓	✓	✓	✓	x	✓	✓	✓
✓	✓	✓	✓	x	✓	✓	✓
✓	✓	✓	○	x	✓	✓	✓
✓	✓	✓	○	x	✓	✓	○
?	?	✓	✓	x	✓	✓	✓
✓	x	✓	✓	?	?	?	✓
✓	x	✓	✓	?	?	?	✓
✓	○	✓	✓	?	?	?	✓
✓	x	?	?	?	?	?	✓
✓	○	?	?	x	x	x	✓
✓	x	?	x	x	x	x	✓
✓	x	✓	✓	x	x	x	✓
✓	x	x	✓	x	x	x	✓
✓	x	○	✓	x	✓	✓	✓
✓	x	x	✓	x	✓	✓	✓
?	x	?	x	x	✓	✓	✓
?	✓	?	x	x	?	?	✓
✓	○	✓	?	x	x	x	✓
?	x	x	x	x	x	x	✓
?	✓	?	?	?	✓	?	✓

Housing

PVDF	Reg. Cel.	Polyester	PC	Acrylic mod.	Polysulfone	Polystyrene	PP
?	○	○	✓	?	?	?	✓
○	x	○	x	✓	✓	✓	✓
○	○	x	x	?	✓	?	✓
○	○	x	x	?	?	?	✓

Housing

PVDF	Reg. Cel.	Polyester	PC	Acrylic mod.	Polysulfone	Polystyrene	PP
?	○	?	✓	✓	✓	✓	✓
✓	✓	✓	✓	✓	✓	✓	✓
?	✓	?	?	✓	✓	✓	✓
?	○	?	?	✓	✓	✓	✓

Housing

PVDF	Reg. Cel.	Polyester	PC	Acrylic mod.	Polysulfone	Polystyrene	PP
✓	?	?	✓	?	✓	?	✓
✓	?	✓	✓	○	✓	x	✓
?	?	✓	✓	x	✓	x	✓
✓	✓	✓	✓	✓	✓	✓	✓
✓	?	✓	✓	?	✓	?	✓
✓	✓	✓	✓	✓	○	○	✓
✓	?	✓	✓	?	✓	?	✓
?	?	✓	✓	x	✓	x	✓
✓	✓	✓	✓	?	✓	?	✓
?	?	✓	✓	x	✓	x	✓

Time of contact: 24 hours to 20 °C

Chemical compatibility depends of several factors

For that, recommend confirm the compatibility with the sample before to start the process of filtration

A.2 Equivalence table

Ashless filter for quantitative analysis

CHMLAB	Filtration Speed	WHATMAN	S&S	M&N	SARTORIUS
F2045	Very fast	-	589/1	640we	388
F2041	Fast	41	589/2	640w	389
F2043	Medium	43	589/5	640m	392
F2040	Medium-slow	40	589/6	640md	390
F2044	Slow	44	589/3	640de	391
F2042	Very slow	42	-	640d	393

Ashless hardened filter paper for quantitative analysis

CHMLAB	Filtration Speed	WHATMAN	S&S	M&N	SARTORIUS
F2141	Medium-fast	541	1505	1640w	1388
F2140	Fast	540	1506	1640m	1392
F2142	Slow	542	1507	1640de	1391

Hardened low ash filter paper for quantitative analysis

CHMLAB	Filtration Speed	WHATMAN	S&S
F2054	Fast	54	1573
F2052	Medium-fast	52	1574
F2050	Slow	50	1575

Ashless hardened filter paper for qualitative analysis

CHMLAB	Filtration Speed	WHATMAN	S&S	M&N	SARTORIUS
F1004	Very fast	4	604	1670/617	288
F1007	Fast	-	597	-	289
F1001	Medium	1	593/595	616/615	292
F1002	Medium-slow	2	-	616md	292a
F1003	Medium/thick	3	591	618	3 S/h
F1006	Slow	6	602h	619eh	290
F1005	Very slow	5	602eh	619de	293

General-purpose qualitative filter paper

CHMLAB	Filtration Speed	WHATMAN	S&S	M&N	SARTORIUS
F1093	Very fast	93	860	617	4b
F1094	Very fast	-	-	-	3m/N
F1113	Extra-fast/Thick	-	3144L	-	-
F1091	Very fast/Crêped	91	0856	-	601/N
F1096	Medium-fast	-	-	-	-
F1095	Fast/Crêped	-	-	-	33/N

Filter paper with diatomaceous

CHMLAB	Filtration Speed	S&S	M&N
F7660	Slow	287	MN660

Filter paper free of K and P, low of N

CHMLAB	Filtration Speed	S&S	M&N	SARTORIUS
F7512	Medium	512	MN616G	132

Black filter paper

CHMLAB	Filtration Speed	WHATMAN	S&S	M&N
F7551	Medium	551	551	MN220

Filter paper for fat analysis

CHMLAB	Filtration Speed	M&N
F7615	Medium	MN615ff

Glass microfiber filters without binders

CHMLAB	WHATMAN	S&S	M&N	SARTORIUS
GF1	GF-A	GF 50	GF1	MGA
GF2	GF-B	GF 51	GF2	MGB
GF3	GF-C	GF 52	GF3	MCG
GF4	GF-D	GF 53	GF4	MGD
GF5	GF-F	GF 55	GF5	MGF
GF6	934-AH	GF 30	GF6	550-HA

Glass microfiber filters with binders

CHMLAB	WHATMAN	S&S	M&N	SARTORIUS
GB04	-	-	MN 85/90	-
GB07	GF9	GF9	MN 85/70	13400
GB10	GF6	GF6	-	-
GB30	GF8	GF8	-	-

Quartz Microfiber filters

CHMLAB	WHATMAN	S&S	M&N	SARTORIUS
QF1	QM-A	QF20	QF10	T293
QF2	-	-	-	MK360

Cellulose extraction thimbles

CHMLAB	WHATMAN	S&S	M&N	SARTORIUS
F5800	2800	603	MN 645	Grade 30
F5810	2810	-	MN 645 F	-

Glass microfiber thimbles

CHMLAB	WHATMAN	S&S	M&N	SARTORIUS
F5900	603g	603g	649	Grade 40

Quartz microfiber thimbles

CHMLAB	WHATMAN	S&S	M&N	SARTORIUS
F5990	603q	603q	-	MK 360

Absorbent paper with Polyethylene

CHMLAB	WHATMAN	S&S	M&N	SARTORIUS
F1505	BENCHKOTE	295PE	210PE	LABSORB
F1506	BENCHKOTE Plus	296PE	-	LABSORB ULTRA

Phase Separation paper

CHMLAB	WHATMAN	S&S	M&N	SARTORIUS
P1000	1PS	597hy	616WA	480

Technical filter papers for special analysis

CHMLAB	Properties	S&S	M&N
F3001	Medium filtration	3205	-
F3002	Absorbent paper	22	MN960
F3003	Slow filtration	-	-
F3004	Non-woven filter	0980/1	-
F3005	Absorbent paper	2282	MN440
F3006	Drying paper	2727	-

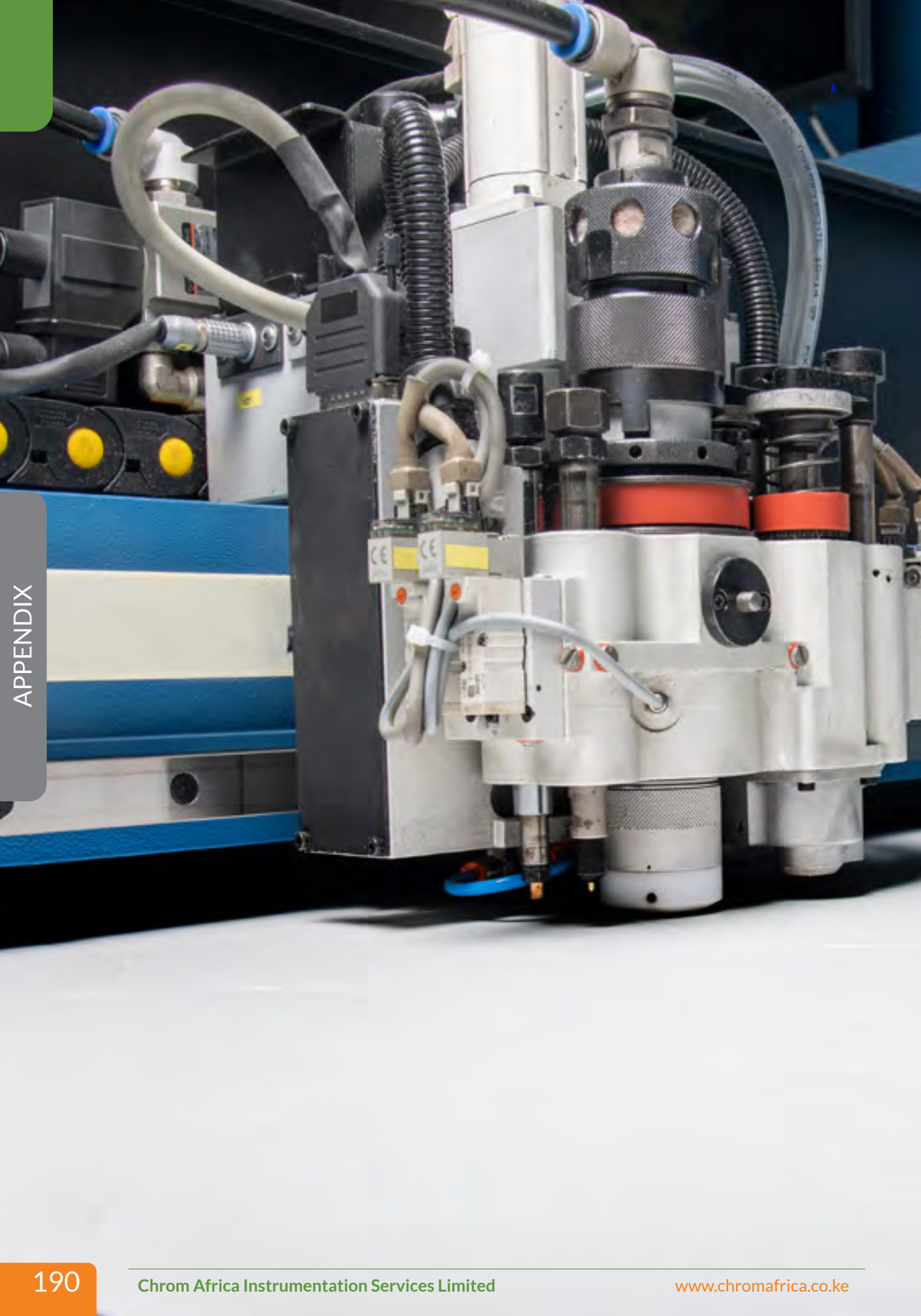

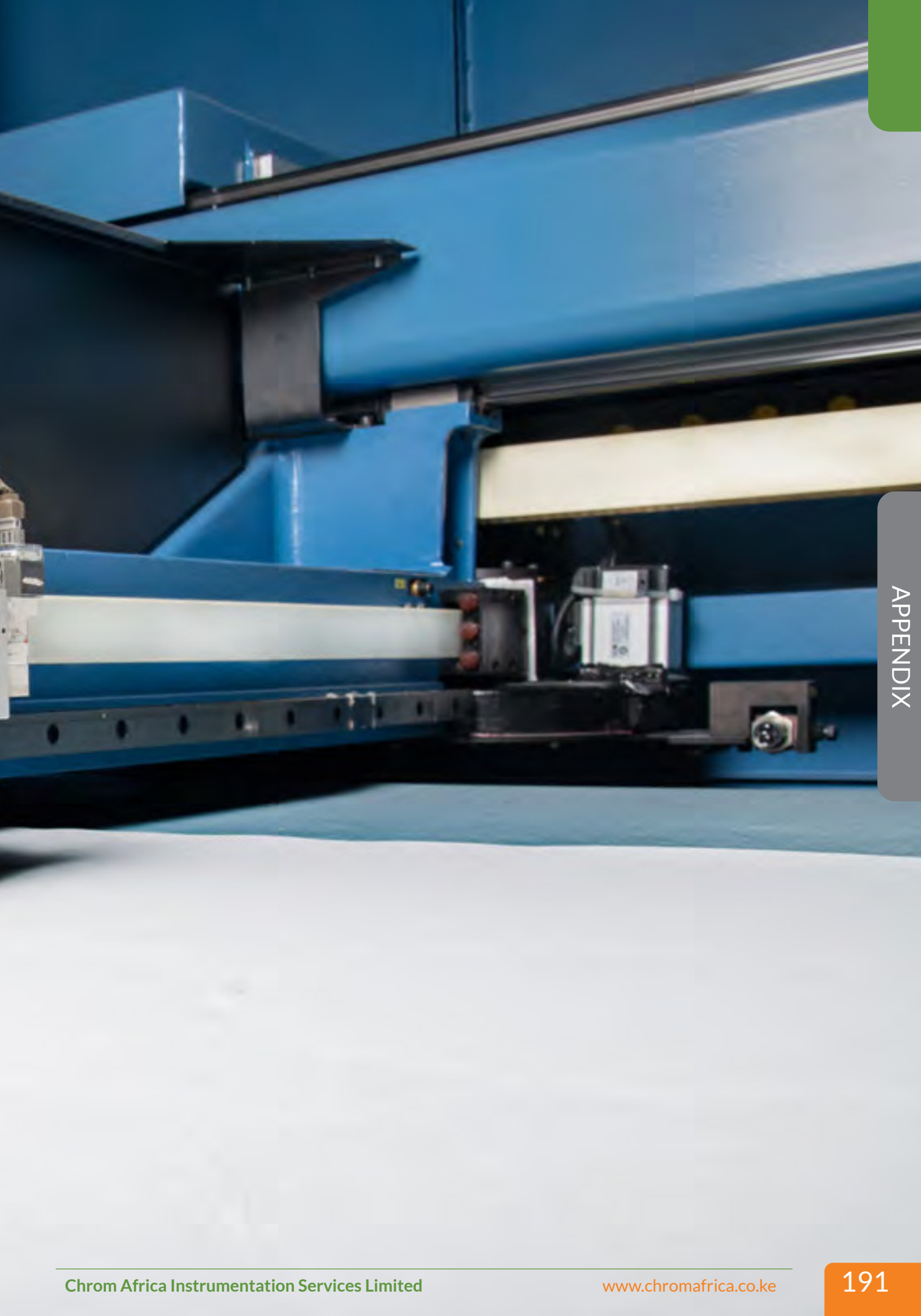



Bringing Scientific & Technical
Resources to the Africa Continent

Chrom Africa Instrumentation Services Limited

Buruburu Business Complex Suite No.26, Mumias South Road, Nairobi.

P.O Box 4963-00100, Nairobi, Kenya.

Phone number: (20) 2594918

Email info@chromafrica.co.ke | info@chromafrica.com

Website: www.chromafrica.co.ke | www.chromafrica.com

